

Hamilton's 98 RH



...replaces virtually any night depository without changes to masonry.

When replacing an old depository:

- No chipping of concrete is required
- All work can be performed from the exterior of the building
- Ideal upgrade where UL specifications must be met
- Designed for industry-standard deposit bags up to 7" x 11"
- Does not require structural changes to building or masonry
- Replaces virtually any night depository
- For both envelope and key-authorized deposits
- Stainless-steel all-weather construction



Actual retrofit—no need to replace chest or chute with 98 RH.



HAMILTON

Hamilton's 98 RH Details

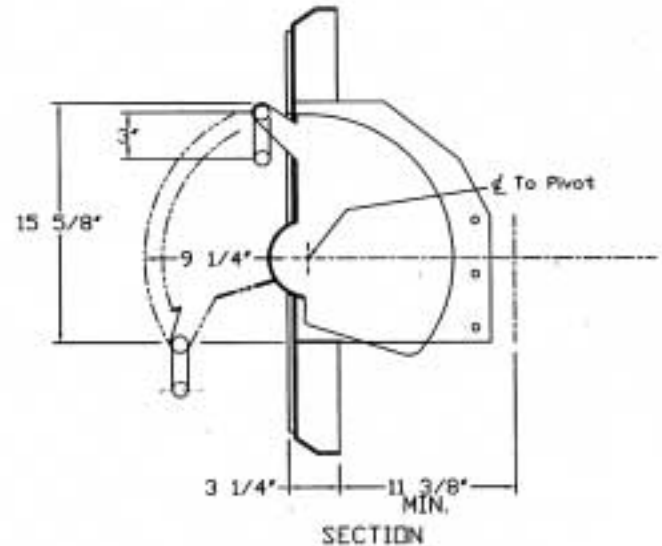
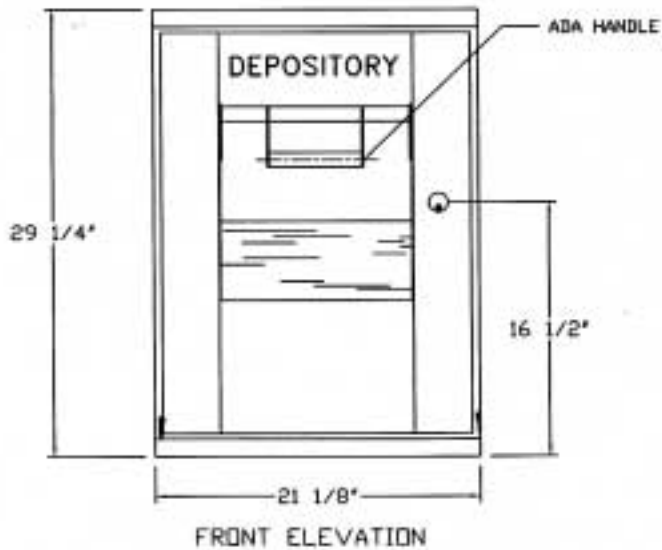
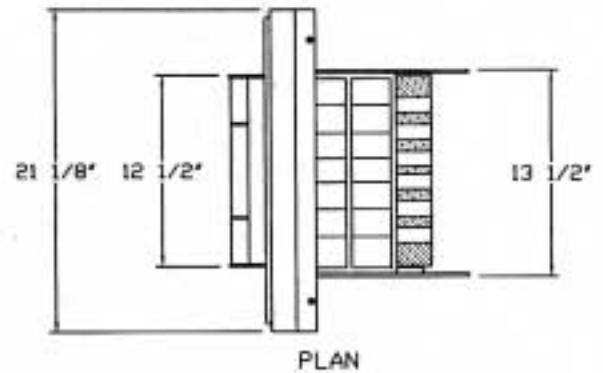
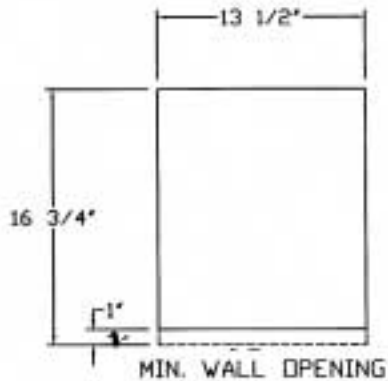

HAMILTON

Manufacturers of the latest in drive-up systems, modular vaults, vault doors, night depositories, physical security containers, alarm systems, coin and currency dispensers, safe deposit boxes and video surveillance equipment.

3143 Production Drive • Fairfield, OH 45014
Telephone: 513/874-3733 • FAX: 513/874-3967
Visit our website at: www.hamiltonsafe.com