

ITEM NO.	PART NUMBER	GAGE	DESCRIPTION	QTY.
1	DD8-67-1	14 GA SS	LATCH MID LINK	1
2	DD8-68-1	14 GA SS	Release Link	1
3	DD8-69-1	14 GA SS	Handle Mount Link	1
4	KSC25C75/Z		1/4-20 x 3/4 SOC, SET SC	1
5	MXF8C31/6S		8-32 x 5/16 PH, FT #6HD	4
6	DD8-SA-019		LATCH ASSEMBLY	1
7	MXT6C12/S-91770A344		6-32 X 1/8" PH, TRS, HD SC	3
8	6046K43		BALL KNOB, LATCH RELEASE HANDLE	1

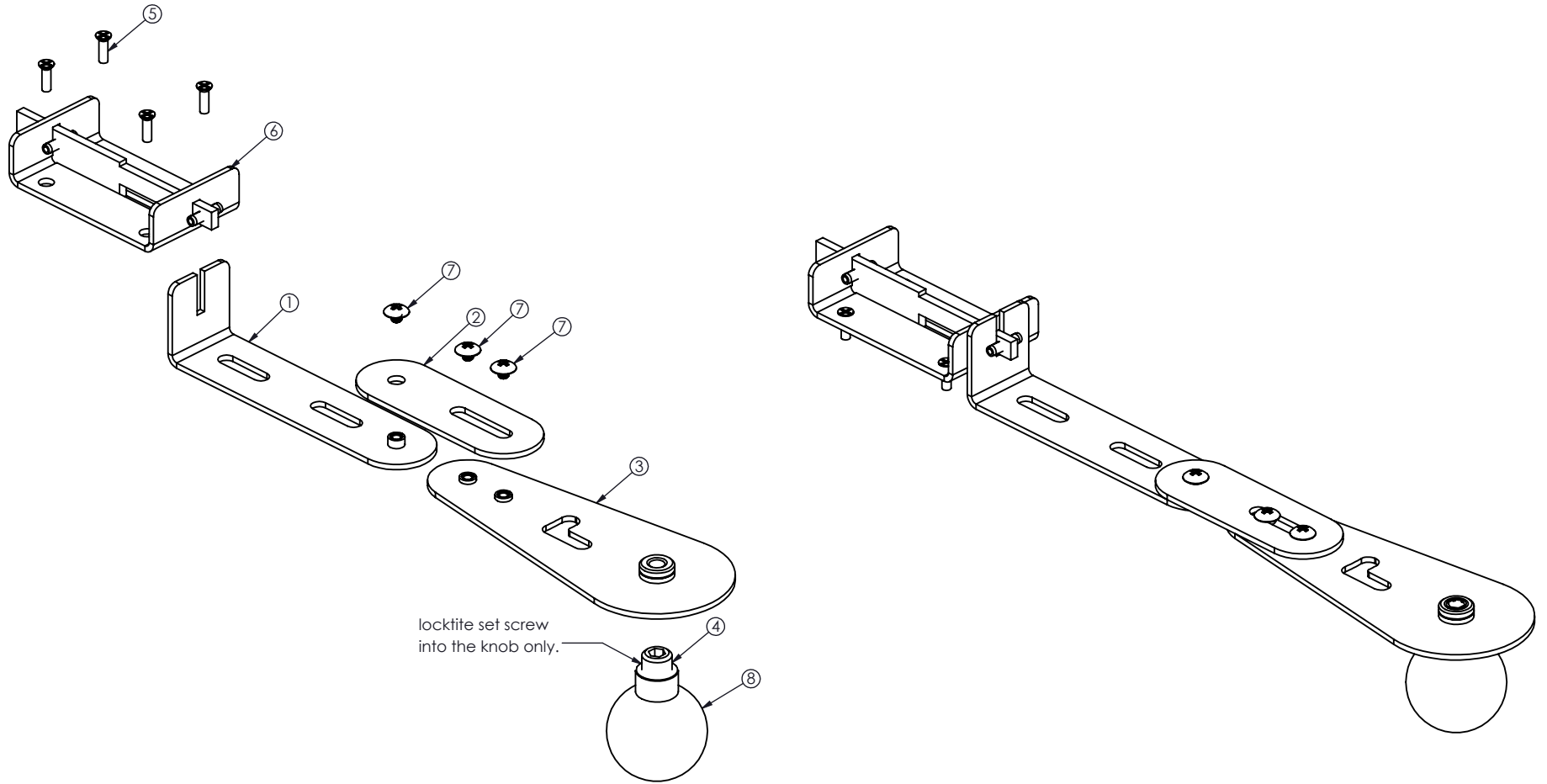

est. 1967 HAMILTON CUSTOM MADE SECURITY	PROPRIETARY AND CONFIDENTIAL THESE DRAWINGS ARE THE PROPERTY OF HAMILTON SAFE CO. AND SHALL NOT BE REPRODUCED, COPIED, USED AS THE BASIS FOR MANUFACTURE OR SALE OF APPARATUS WITHOUT PERMISSION		TITLE LATCH ASSEMBLY, DRAWER LATCH	
	All Weld Notes Comply With AWS A2.4-98 Standards		PART NUMBER DD8-SA-005	
DRAWN BY DPC		DATE 2/10/2021	CHECKED BY	DATE
			REVISION	