

Top Cap Assembly

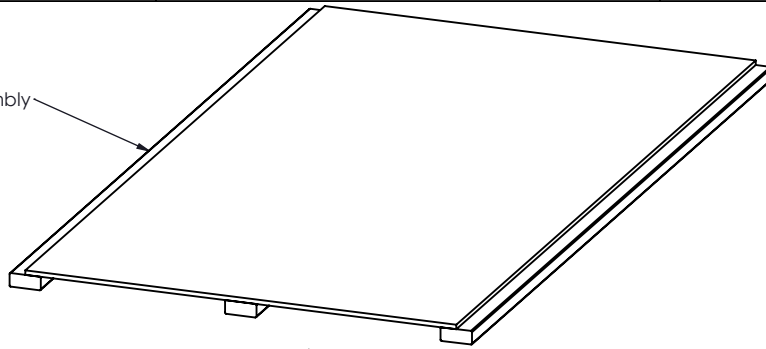

Loose Lumber		
Material	Size	QTY
2 x 4	51.5"	5
2 x 4	88.25"	2
7/16" OSB	24" x 88.25"	2
Assemblies		
Skid	Detail on Sheet 2	1
End Cap	Detail on Sheet 3	2
Top Cap	Detail on Sheet 4	1

5 "2 x 4" x 51.5

Skid Assembly

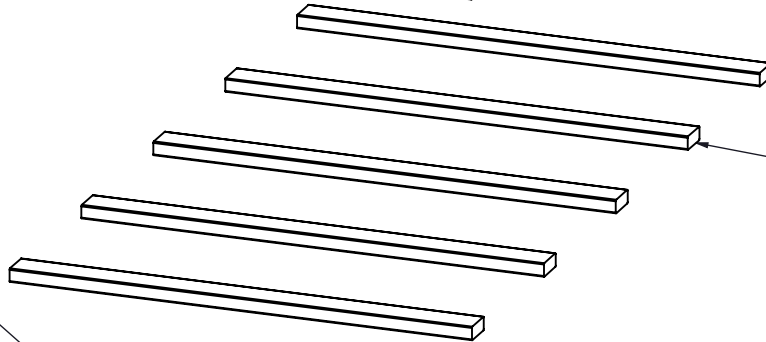

2 x End Cap Assembly

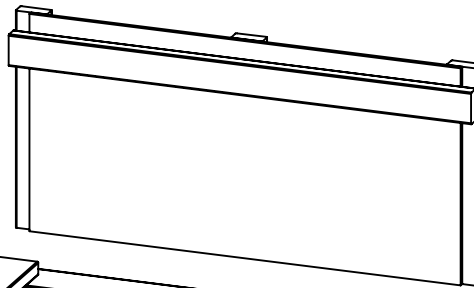

2 x "2 x 4" x 88.25"

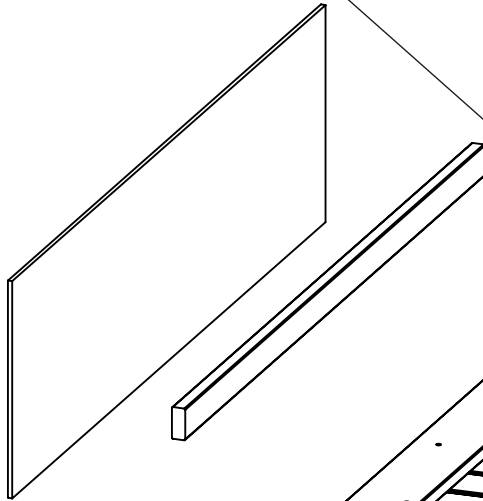

2 x 7/16" OSB 24" x 88.25"

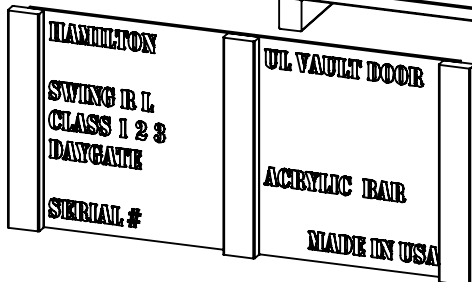
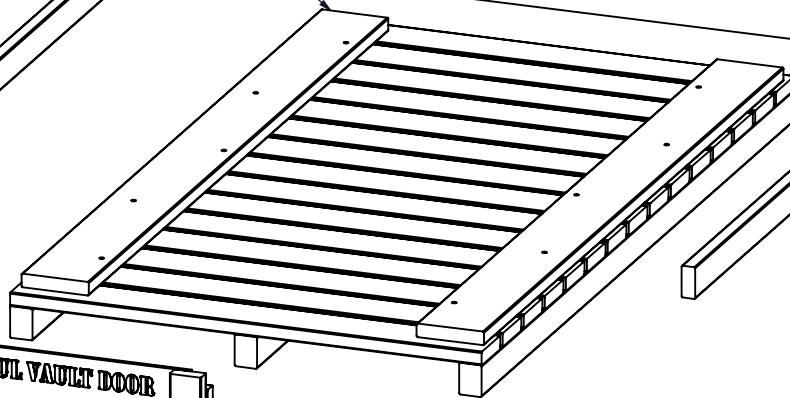

Sheet 1 of 4

est. 1967 HAMILTON CUSTOM MADE SECURITY	PROPRIETARY AND CONFIDENTIAL THESE DRAWINGS ARE THE PROPERTY OF HAMILTON SAFE CO. AND SHALL NOT BE REPRODUCED, COPIED, USED AS THE BASIS FOR MANUFACTURE OR SALE OF APPARATUS WITHOUT PERMISSION	TITLE	
		Vault Door Skid & Crate, Hyde Park	
All Weld Notes Comply With AWS A2.4-98 Standards	DRAWN BY BilDef	PART NUMBER	
		HUD-SKID	
		DATE	REVISION
		6/1/2022	

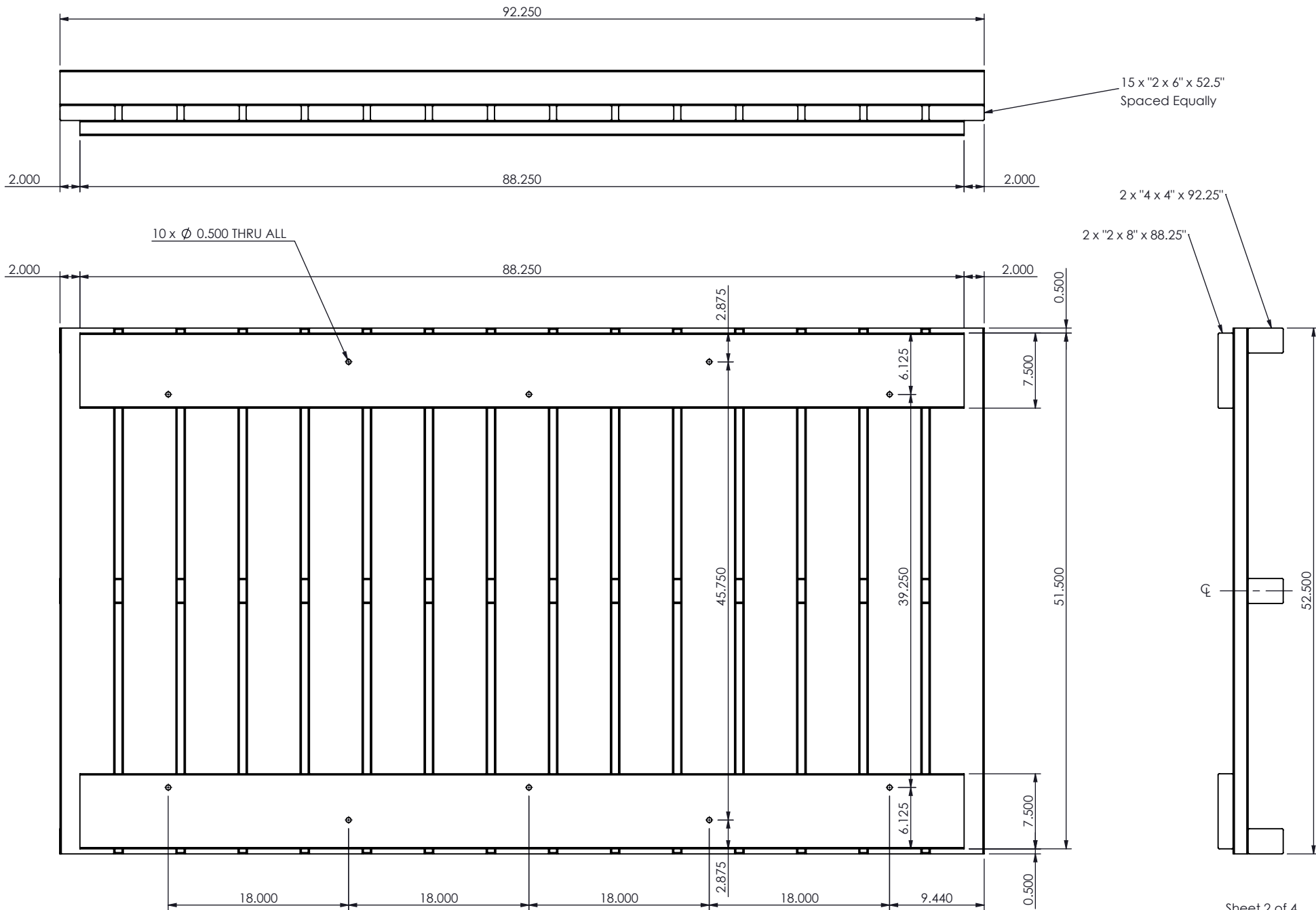

Sheet 2 of 4

est. 1967 HAMILTON CUSTOM MADE SECURITY	PROPRIETARY AND CONFIDENTIAL THESE DRAWINGS ARE THE PROPERTY OF HAMILTON SAFE CO. AND SHALL NOT BE REPRODUCED, COPIED, USED AS THE BASIS FOR MANUFACTURE OR SALE OF APPARATUS WITHOUT PERMISSION		TITLE Vault Door Skid Details, Hyde Park	
	All Weld Notes Comply With AWS A2.4-98 Standards		PART NUMBER HUD-SKID	
DRAWN BY BilDet		DATE 6/1/2022		CHECKED BY
				DATE
				REVISION

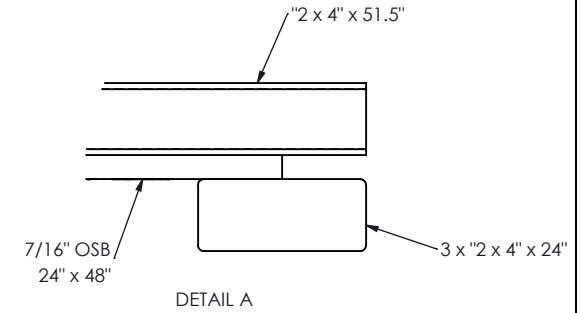
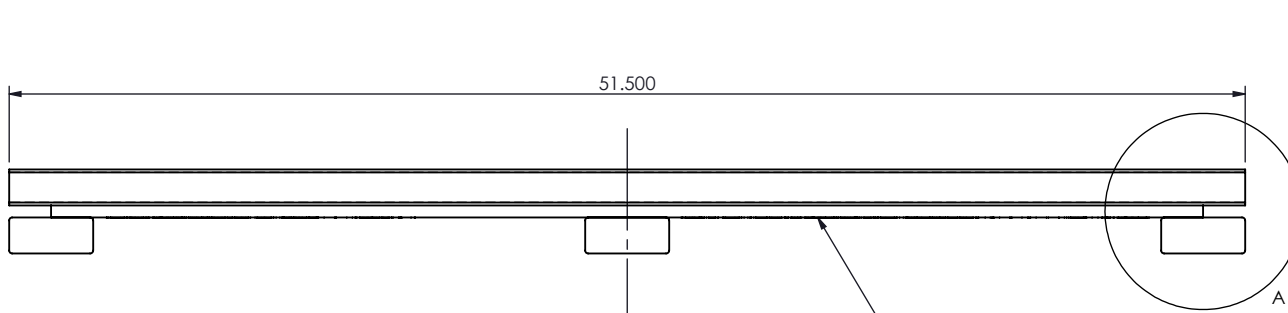

Black Stenciled Lettering

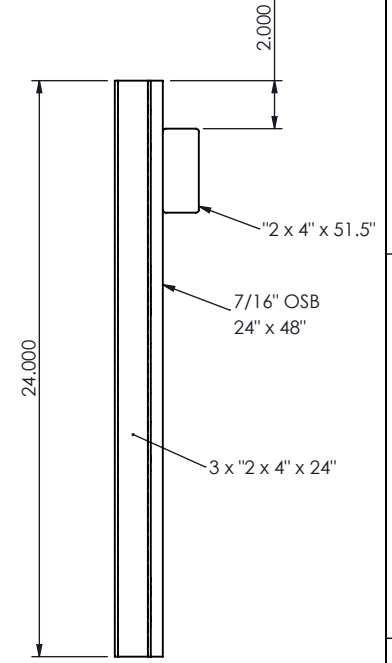
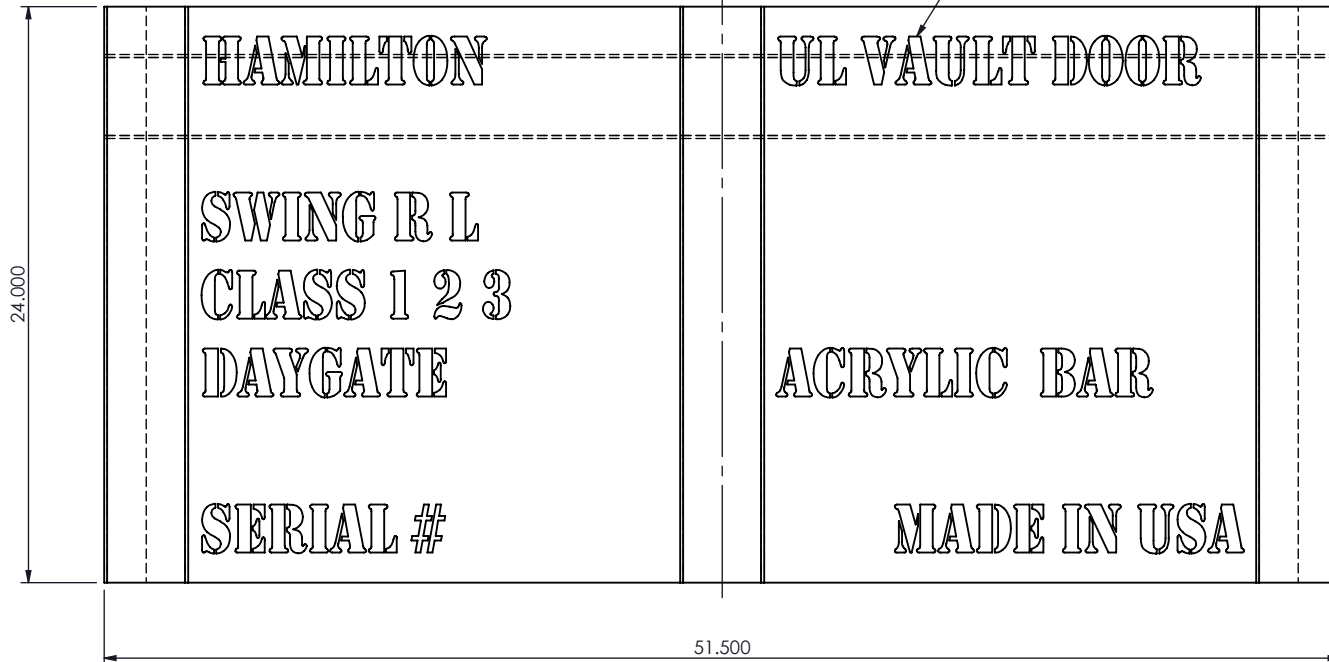

Two End Cap Assemblies Req'd per Crate

Sheet 3 of 4

est. 1967 HAMILTON CUSTOM MADE SECURITY	PROPRIETARY AND CONFIDENTIAL THESE DRAWINGS ARE THE PROPERTY OF HAMILTON SAFE CO. AND SHALL NOT BE REPRODUCED, COPIED, USED AS THE BASIS FOR MANUFACTURE OR SALE OF APPARATUS WITHOUT PERMISSION	TITLE Vault Door Crate End Cap Details, Hyde Park	
	All Weld Notes Comply With AWS A2.4-98 Standards	DRAWN BY BilDet	DATE 6/1/2022

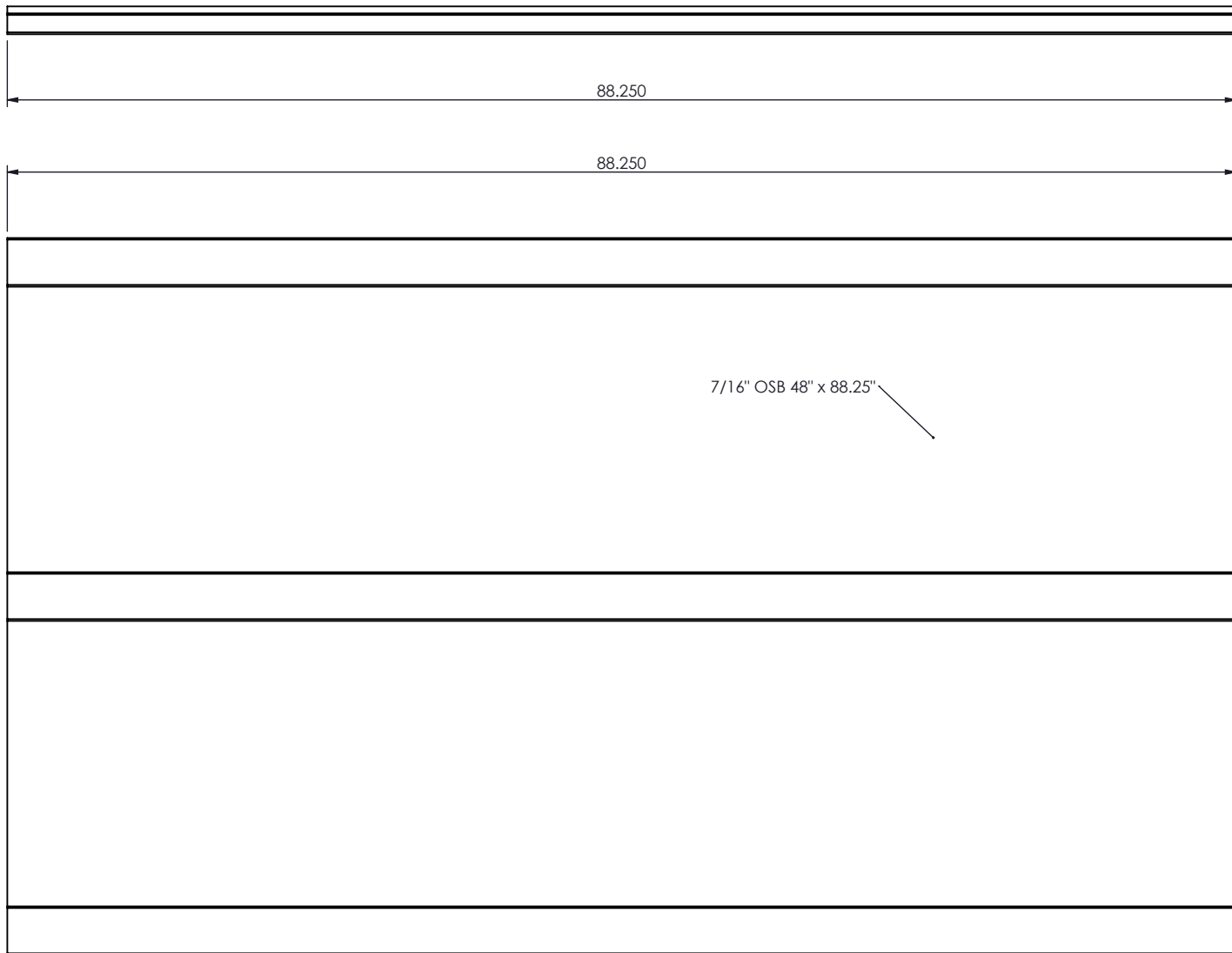

3 x "2 x 4" x 88.25"

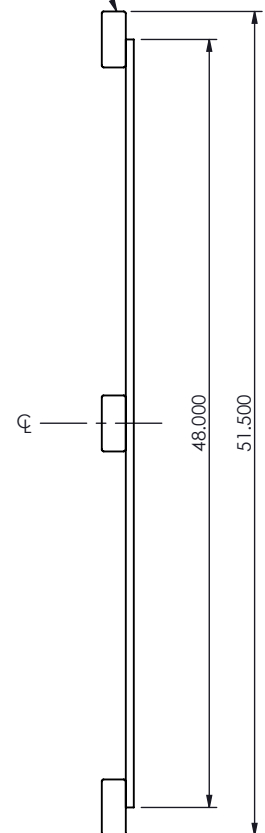

Sheet 4 of 4

est. 1967 HAMILTON CUSTOM MADE SECURITY	PROPRIETARY AND CONFIDENTIAL THESE DRAWINGS ARE THE PROPERTY OF HAMILTON SAFE CO. AND SHALL NOT BE REPRODUCED, COPIED, USED AS THE BASIS FOR MANUFACTURE OR SALE OF APPARATUS WITHOUT PERMISSION	TITLE Vault Door Crate Top Cap Details, Hyde Park	
	All Weld Notes Comply With AWS A2.4-98 Standards	DRAWN BY BilDef	DATE 6/1/2022