

ITEM NO.	PartNo	DESCRIPTION	QTY.
1	ND21-HOP-WSA	Hopper Welded Sub-Assembly	1
2	ND21-GATE-WSA	Ejector Gate Welded Sub-Assembly	1
3	ND21-024	Front Panel, Hopper	1
4	ND21-076	Roller, Ejector Gate	1
5	ND21-079	Links, Swing Handle	2
6	ND21-092	Pivot Axle, Main Hopper	1
7	ND21-101	Thrust Washer, Hopper Pivot	3
8	ND21-147	Gate Pivot Shaft, ND21	1
9	ND21-155	Linear Speed Limiter 2" x 50lb. Comp Force	1
10	B3798	80UC ADA Handle Center Section	2
11	8926T23	Bumper with Threaded Hole	1
12	6381K553	Sleeve Bearing, 3/4"ID x 1"ODx5/8"Lg	1
13	MXF25C37/UCS	1/4"-20 x 3/8 Undercut Flat Head Phillips (SS)	1
14	MXF8C25/Z	8-32 x 1/4 Phillips Flat Head (Zinc)	4
15	KBC37C62/S	3/8-16 x 5/8 SBHCS (SS)	2
16	KSS50R31/S	1/2 x 5/16 Shoulder Screw (SS)	2
17	NNE31C/Z	5/16-18 Steel Nylon-Insert Locknut (Zinc)	2
18	KSC31C125	5/16"-18 x 1-1/4" Cup Point Set Screw	2
19	5160-62	5/8" Heavy Duty External Retaining Ring	2
20	6338K575	5/8 x 3/4 x 1/2 Flanged Sleeve Bearing	2
22	90218A314	Reusable Push-In Rivets with Arrow Shank	1
23	ND21-194	Power Fail Hole Plug	1

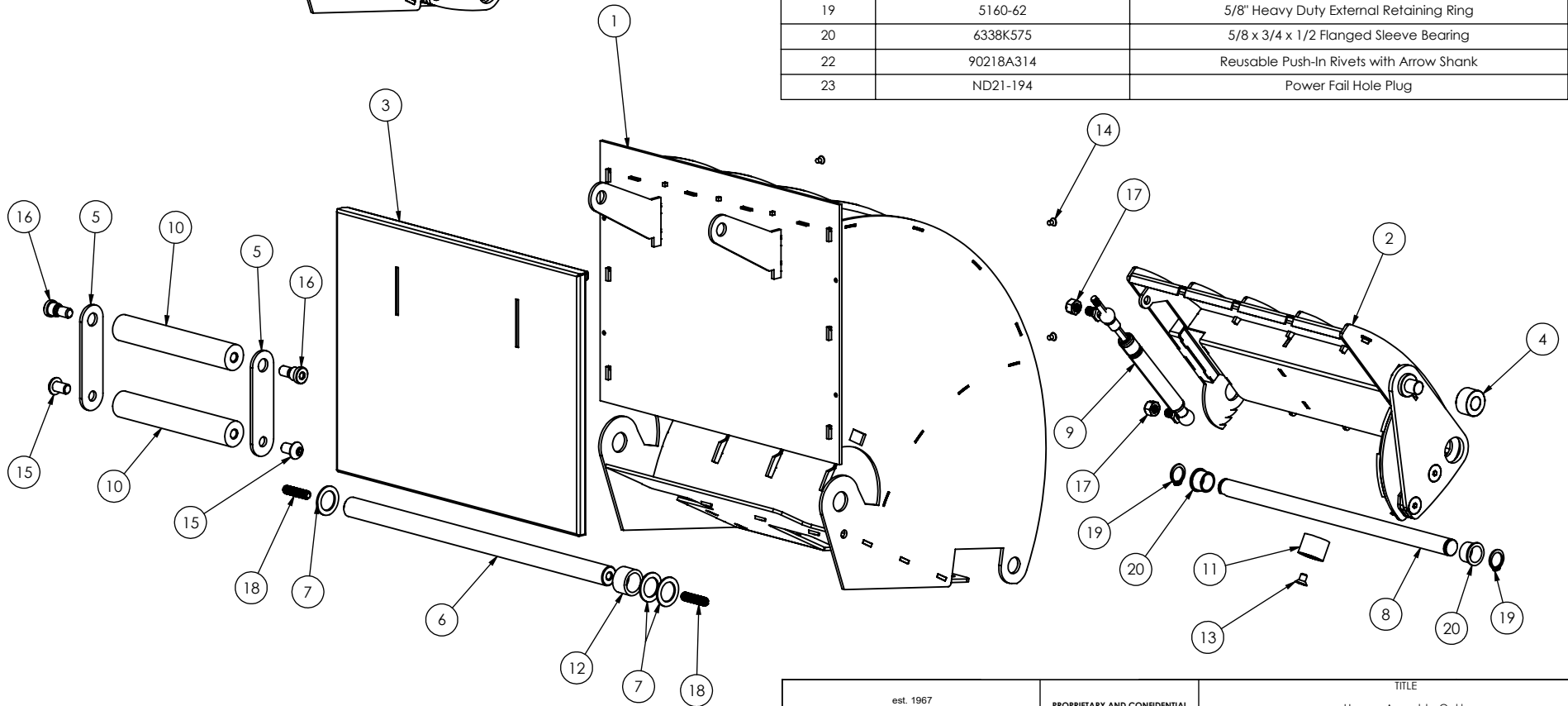

est. 1967 HAMILTON CUSTOM MADE SECURITY	PROPRIETARY AND CONFIDENTIAL THESE DRAWINGS ARE THE PROPERTY OF HAMILTON SAFE CO. AND SHALL NOT BE REPRODUCED, COPIED, USED AS THE BASIS FOR MANUFACTURE OR SALE OF APPARATUS WITHOUT PERMISSION		TITLE Hopper Assembly, Oakley	
	PART NUMBER OAK-HOPPER		DRAWN BY BilDef	
DATE 6/16/2022		CHECKED BY DATE		REVISION

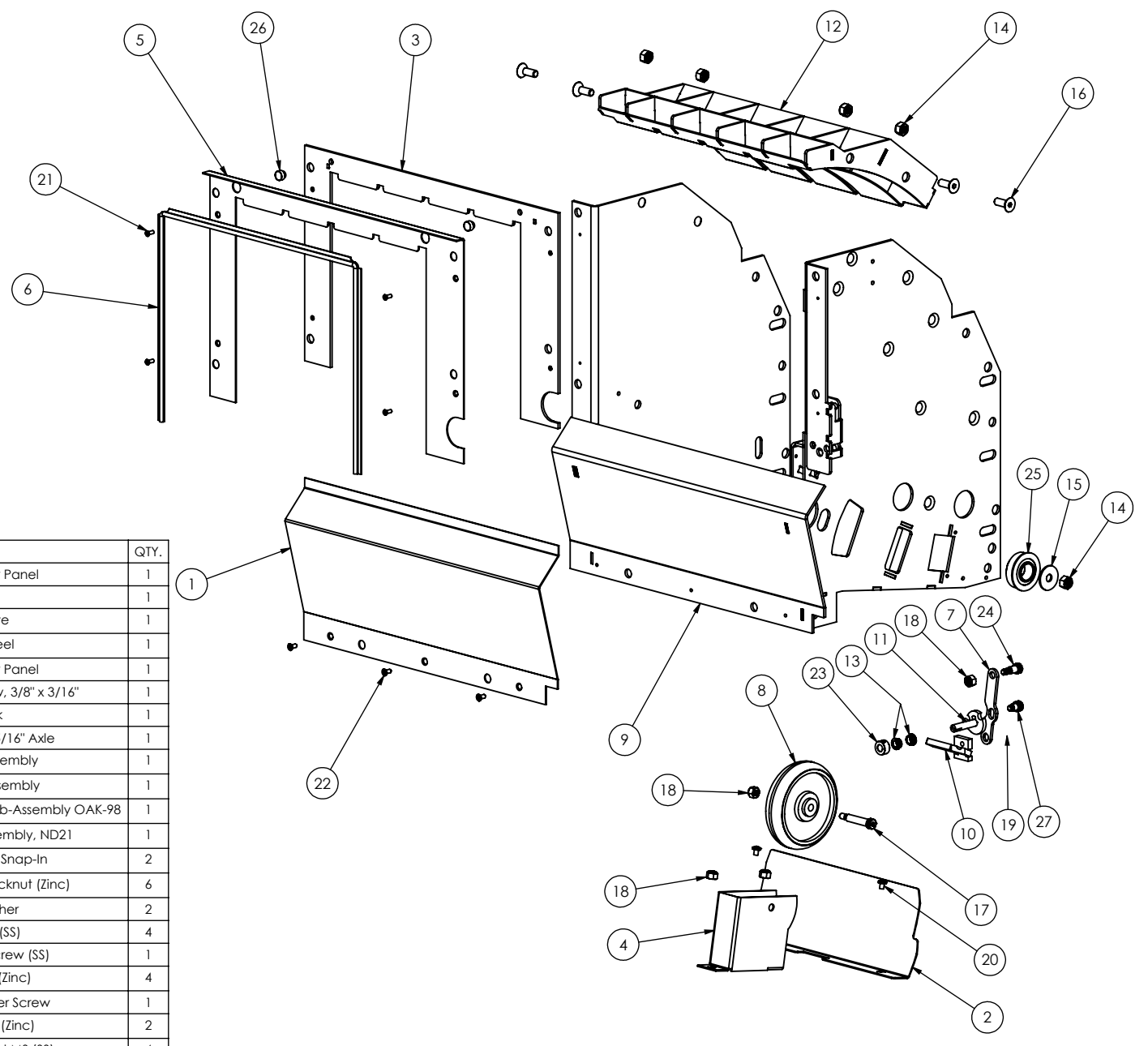

ITEM NO.	PartNo	DESCRIPTION	QTY.
1	ND21-025	Face, Bulkhead Center Panel	1
2	ND21-026	Deflector Plate	1
3	ND21-032	Bulkhead, Top Plate	1
4	ND21-050	Mount, Ejector Wheel	1
5	ND21-060	Face, Bulkhead Center Panel	1
6	ND21-090	1129A991 Rubber Seal, Hollow, 3/8" x 3/16"	1
7	ND21-114	Lock Acuator Link	1
8	ND21-154	4" x 1" Rubber Wheel For 5/16" Axle	1
9	OAK-FRM-WSA	Frame Welded Sub-Assembly	1
10	ND21-LPIN-WSA	Locking Pin Welded Assembly	1
11	ND21-LSFT-WSA-98	Lock Bolt Cam and Shaft Welded Sub-Assembly OAK-98	1
12	ND21-STS-WSA	Top Sweep Welded Sub-Assembly, ND21	1
13	H1009	5/16" ID Shaft Grommet, Snap-In	2
14	NNE31C/Z	5/16-18 Steel Nylon-Insert Locknut (Zinc)	6
15	WFE31N/125Z	5/16" Wide Flat Washer	2
16	KCS31C87/S	5/16-18 x 7/8 SFHCS (SS)	4
17	KSS31R137/S	5/16" x 1-3/8" Shoulder Screw (SS)	1
18	NNE25C/Z	1/4-20 Nylon Locknut (Zinc)	4
19	KSS31R50	5/16 x 1/2 Socket Shoulder Screw	1
20	MXP10F25/Z	10-32 x 1/4 Phillips Pan (Zinc)	2
21	MXF6C37/Z	6-32 x 3/8 Phillips Flat Head MS (SS)	4
22	MXF8C37/UCS	8-32 x 3/8 Undercut Phillips Flat Head Stainless Steel	3
23	SC31/1	5/16" Shaft Collar (Zinc)	1
24	KSS31R37	5/16 x 3/8 Socket Shoulder Screw	1
25	6384K367	3/4"IDx1-5/8"OD Flanged Ball Bearing	2
26	9309K36	Tight-Grip Push-In Bumpers	2
27	94361A121	5/16 x 1/4 Short-Thread Shoulder Screw	1

est. 1967 HAMILTON CUSTOM MADE SECURITY	PROPRIETARY AND CONFIDENTIAL THESE DRAWINGS ARE THE PROPERTY OF HAMILTON SAFE CO. AND SHALL NOT BE REPRODUCED, COPIED, USED AS THE BASIS FOR MANUFACTURE OR SALE OF APPARATUS WITHOUT PERMISSION		TITLE Frame Assembly, Oakley	
	PART NUMBER OAK-FRAME		DRAWN BY BilDef	
		DATE 8/4/2022	CHECKED BY	DATE
		REVISION		

ITEM NO.	PartNo	DESCRIPTION	QTY.
1	ND21-006	Gate Guide Outer Track	1
2	ND21-099	Spacer, Gate Guide	4
3	ND21-143	Spacer Washer, Open Bumper	1
4	OAK-ASSIST	Assist Mechanism, Night Depository	1
5	OAK-DTNT	Detent Assembly, Oakley	1
6	OAK-FRM-WSA	Frame Welded Sub-Assembly	1
7	KFC31C62	5/16-18 x 5/8 SFHCS	6
8	KCS25C50/Z	1/4-20 x 1/2 SHCS	1
9	93115K221	Bumper, 1" x 3/4" High 1/4-20 Thread	1
10	8507K45	U-Channel Trim, 1/4" x 1/2" Inside, 2-1/2" Long	1
11	ND21-125	Lock Pin, ND21	1
12	ND21-126	Anchor Block, Lock Pin	1

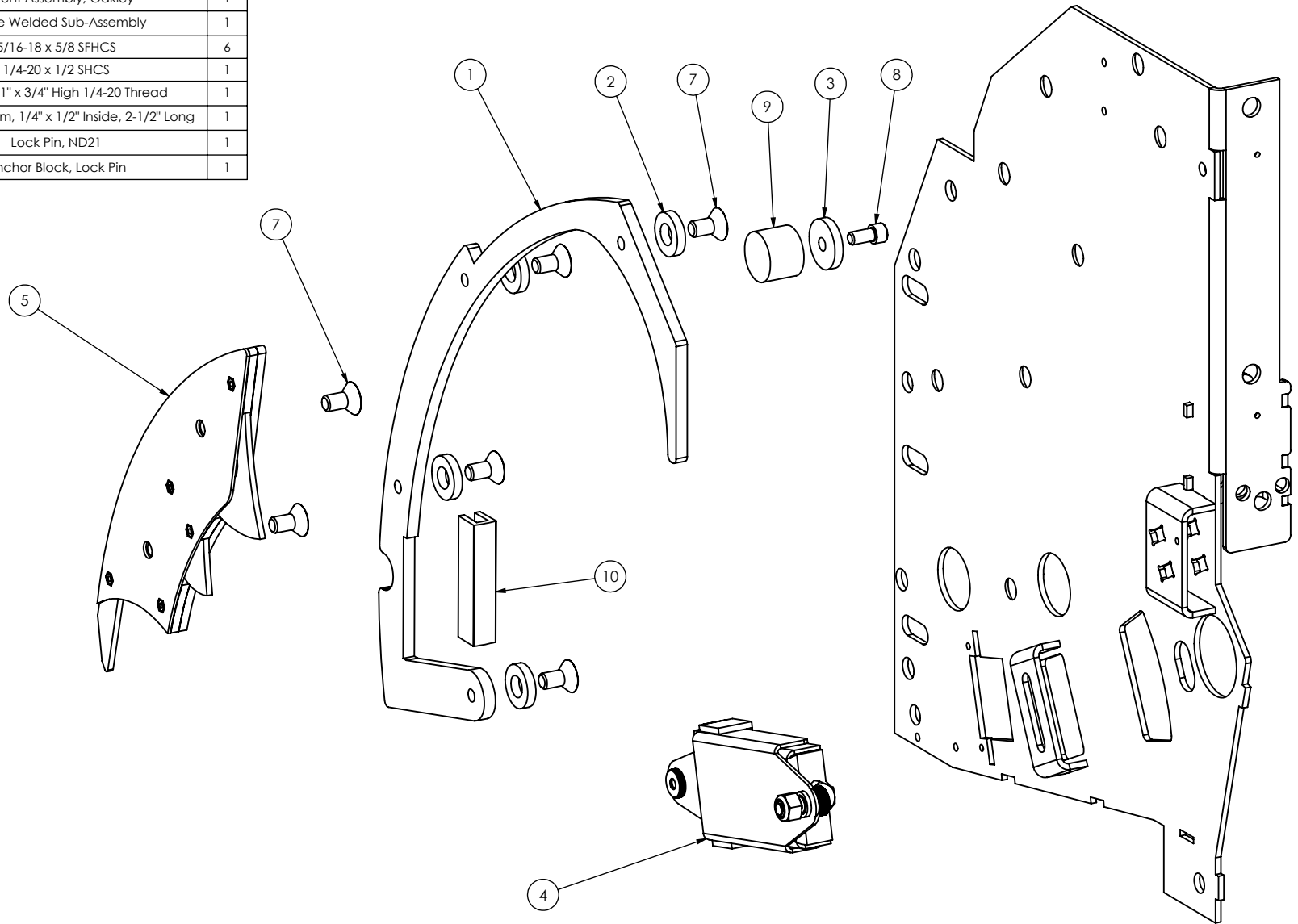

est. 1967 HAMILTON CUSTOM MADE SECURITY	PROPRIETARY AND CONFIDENTIAL THESE DRAWINGS ARE THE PROPERTY OF HAMILTON SAFE CO. AND SHALL NOT BE REPRODUCED, COPIED, USED AS THE BASIS FOR MANUFACTURE OR SALE OF APPARATUS WITHOUT PERMISSION		TITLE Inner Frame Assembly, Oakley	
	PART NUMBER OAK-IN-FRAME		DRAWN BY BilDet	DATE 8/4/2022
		DATE 	REVISION 	

ITEM NO.	PartNo	DESCRIPTION	QTY.
1	ND21-034	Detent Main Plate	1
2	ND21-035	Detent Mid Plate	1
3	ND21-033	Detent Cover Plate	1
4	ND21-103	Lever 1, Detent	1
5	ND21-102	Lever 2, Detent	1
6	ND21-036	Lever 2, Detent	1
7	MXF6C37/Z	6-32 x 3/8 Phillips Flat Head MS (SS)	4
8	WUS10N/Z	#10 (3/16) USS Flat Washer - Z	1

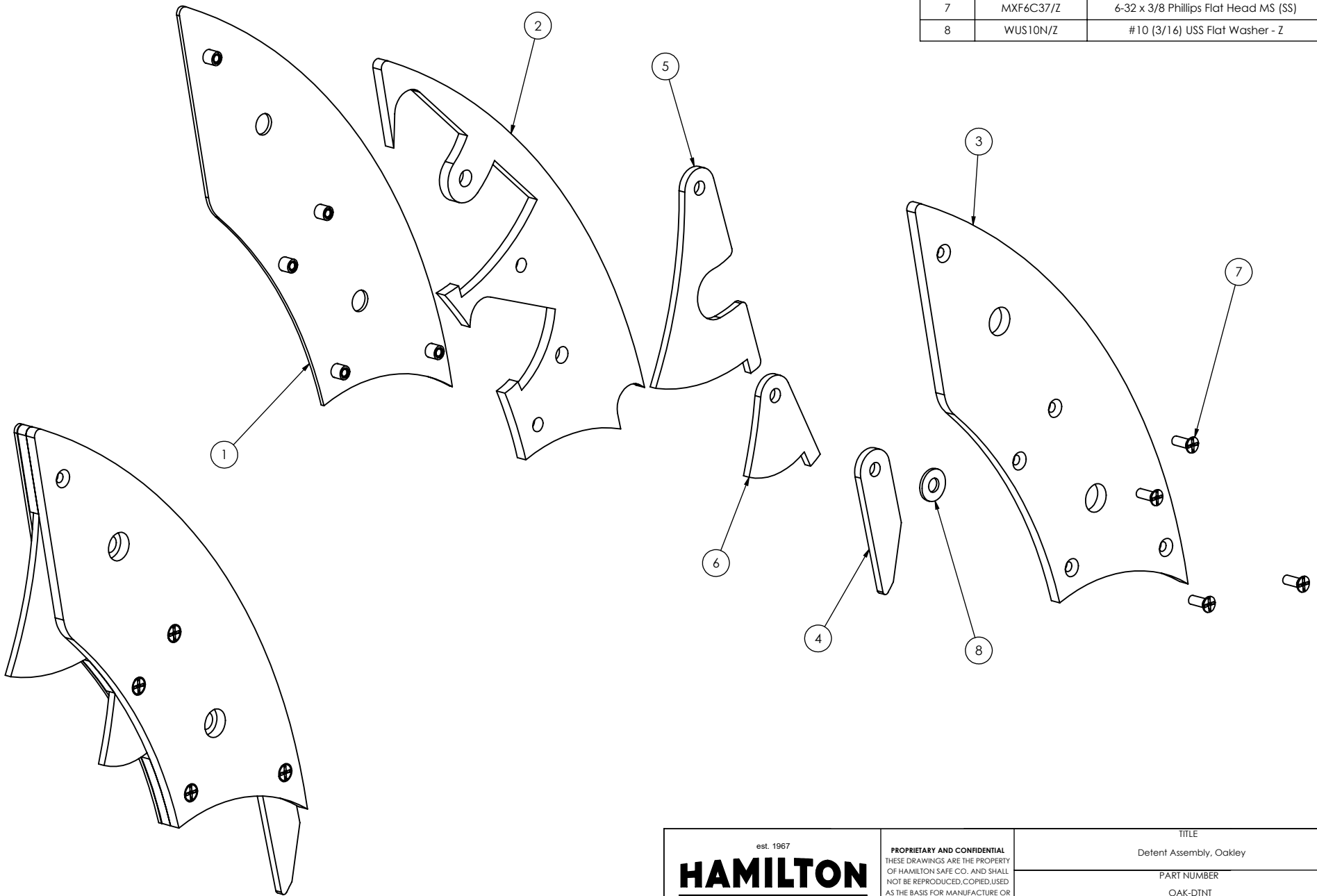

est. 1967 HAMILTON CUSTOM MADE SECURITY	PROPRIETARY AND CONFIDENTIAL THESE DRAWINGS ARE THE PROPERTY OF HAMILTON SAFE CO. AND SHALL NOT BE REPRODUCED, COPIED, USED AS THE BASIS FOR MANUFACTURE OR SALE OF APPARATUS WITHOUT PERMISSION		TITLE Detent Assembly, Oakley	
	PART NUMBER OAK-DTNT		REVISION A	
DRAWN BY BilDet	DATE	CHECKED BY	DATE	REVISION A

ITEM NO.	PartNo	DESCRIPTION	QTY.
1	ND21-073	Main Support Bracket, 5lb Assist	1
2	ND21-ASST-WSA	Assist Support Bracket Welded Sub-Assembly	1
3	ND21-156	Blue Chrome-Silicon Steel Die Spring	1
4	NFJ37C/Z	3/8-16 Hex Jam Nut (Zinc)	3
5	WUS31N/Z	5/16" Flat Washer	1
6	ND21-167	Detent Spring Alignment Bolt	1

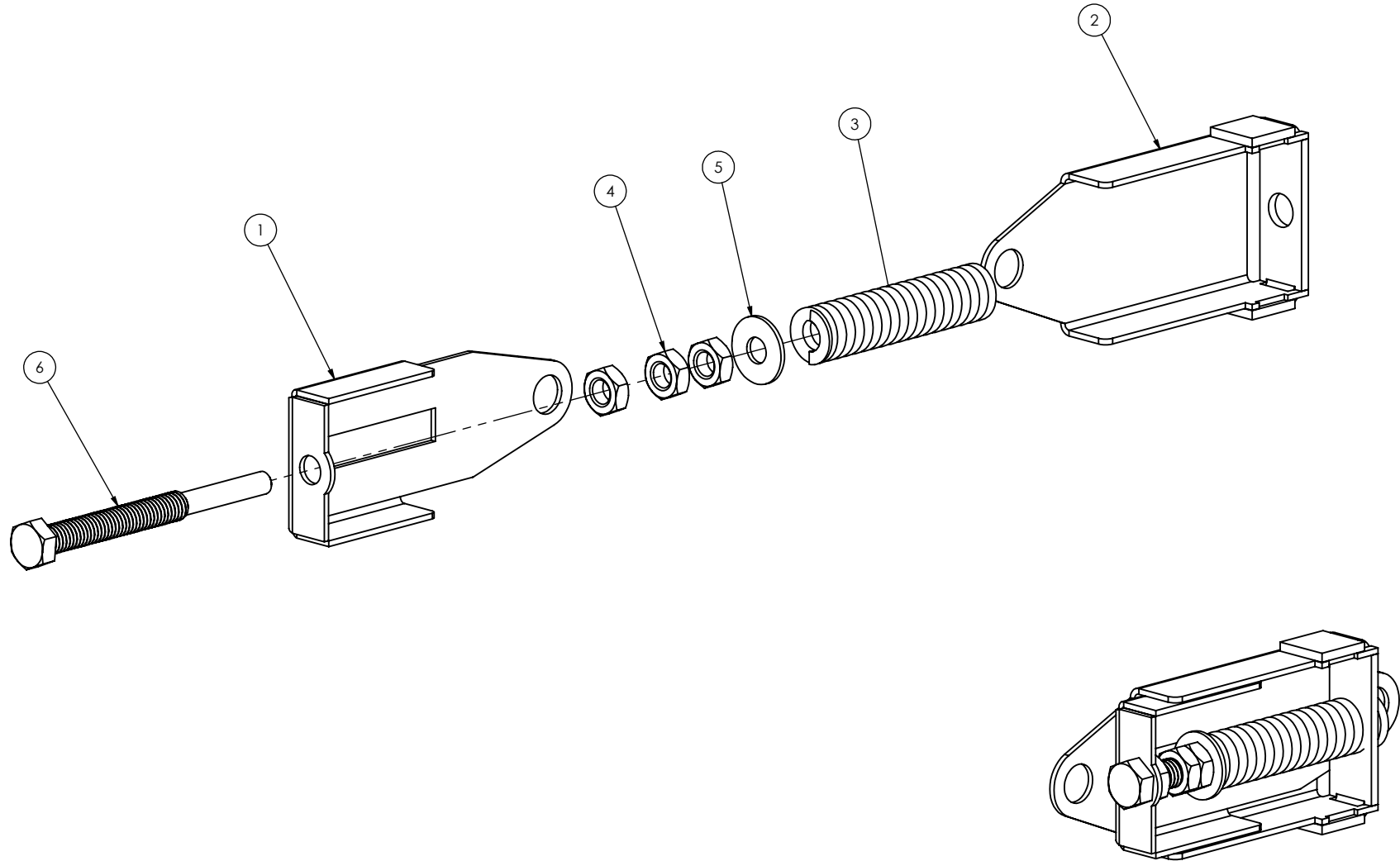

est. 1967 HAMILTON CUSTOM MADE SECURITY	PROPRIETARY AND CONFIDENTIAL THESE DRAWINGS ARE THE PROPERTY OF HAMILTON SAFE CO. AND SHALL NOT BE REPRODUCED, COPIED, USED AS THE BASIS FOR MANUFACTURE OR SALE OF APPARATUS WITHOUT PERMISSION		TITLE Assist Assembly, Oakley	
	PART NUMBER OAK-ASSIST		DRAWN BY BilDef	DATE 9/22/2022
		DATE 	REVISION 	

ITEM NO.	PartNo	DESCRIPTION	QTY.
1	ND21-145	Bulkhead Backing Plate, OAK-98	1
2	ND21-144	Bulkhead Cover Stainless Steel, O-98 Fascia	1
3	ND21-113	Bulkhead Side Plate, OAK-98	2
4	ND21-115	Lock Anchor Plate, OAK-98 & 20	1
5	ND21-129	Lock Spacer Bracket, OAK-98 & 20	1
6	ND21-116	Face, OAK-98 Right Side, Keylock	1
7	ND21-117	Side Panel, OAK-98 Fascia Left	1
8	ND21-119	Top Center, OAK-98 Fascia	1
9	ND21-120	Bottom Center, OAK-98 Fascia	1
10	ND21-121	Logo Backer Panel, OAK-98	1
11	ND21-122	Camera Bracket, OAK-98	1
12	MXP10F37/Z	10-32 x 3/8 Phillips Pan (Zinc)	2
13	KBC25C100/S	1/4-20 x 1 SBHCS (SS)	10
14	NKE25C/Z	1/4-20 Keps Nut - Zinc	10
15	MXF10F75/Z	10-32 x 3/4 Phil FHMS; Zinc	22
16	AKS4-1032-130	10-32 AVK Steel Open End A-k Series Insert Zinc Dichromat	22

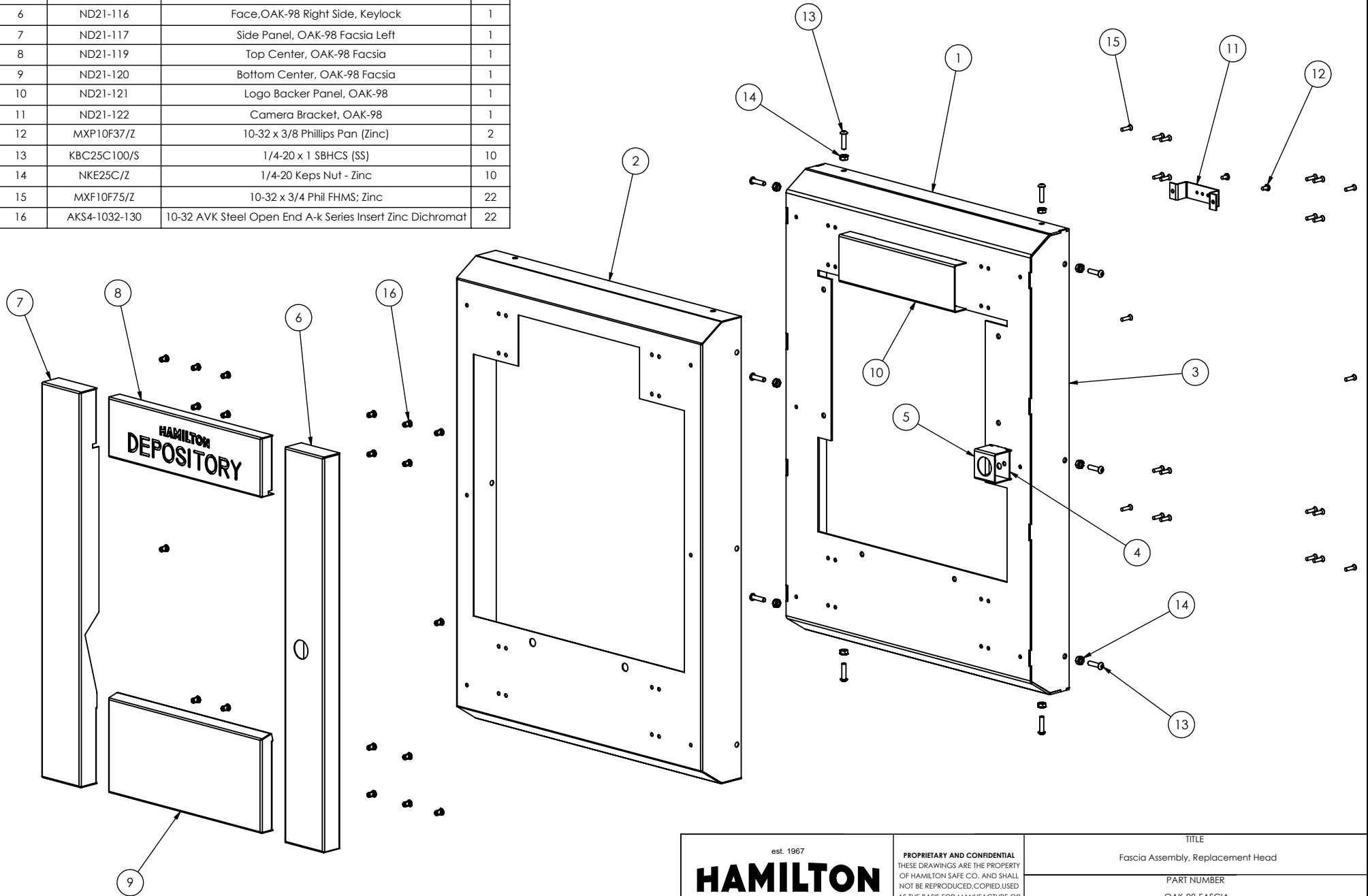

est. 1967 HAMILTON CUSTOM MADE SECURITY	PROPRIETARY AND CONFIDENTIAL THESE DRAWINGS ARE THE PROPERTY OF HAMILTON SAFE CO. AND SHALL NOT BE REPRODUCED, COPIED, USED AS THE BASIS FOR MANUFACTURE OR SALE OF APPARATUS WITHOUT PERMISSION		TITLE Fascia Assembly, Replacement Head	
	PART NUMBER OAK-98-FASCIA		DRAWN BY BilDef	
DATE 9/28/2022		CHECKED BY		REVISION