

ITEM NO.	PartNo	DESCRIPTION	QTY.
1	ND21-HOP-WSA	Hopper Welded Sub-Assembly	1
2	ND21-GATE-WSA	Ejector Gate Welded Sub-Assembly	1
3	ND21-024	Front Panel, Hopper	1
4	ND21-076	Roller, Ejector Gate	1
5	ND21-079	Links, Swing Handle	2
6	ND21-092	Pivot Axle, Main Hopper	1
7	ND21-101	Thrust Washer, Hopper Pivot	3
8	ND21-147	Gate Pivot Shaft, ND21	1
9	ND21-155	Linear Speed Limiter 2" x 50lb. Comp Force	1
10	B3798	80UC ADA Handle Center Section	2
11	8926T23	Bumper with Threaded Hole	1
12	6381K553	Sleeve Bearing, 3/4"ID x 1"ODx5/8"Lg	1
13	MXF25C37/UCS	1/4"-20 x 3/8 Undercut Flat Head Phillips (SS)	1
14	MXF8C25/Z	8-32 x 1/4 Phillips Flat Head (Zinc)	4
15	KBC37C62/S	3/8-16 x 5/8 SBHCS (SS)	2
16	KSS50R31/S	1/2 x 5/16 Shoulder Screw (SS)	2
17	NNE31C/Z	5/16-18 Steel Nylon-Insert Locknut (Zinc)	2
18	KSC31C125	5/16"-18 x 1-1/4" Cup Point Set Screw	2
19	5160-62	5/8" Heavy Duty External Retaining Ring	2
20	6338K575	5/8 x 3/4 x 1/2 Flanged Sleeve Bearing	2
22	90218A314	Reusable Push-In Rivets with Arrow Shank	1
23	ND21-194	Power Fail Hole Plug	1

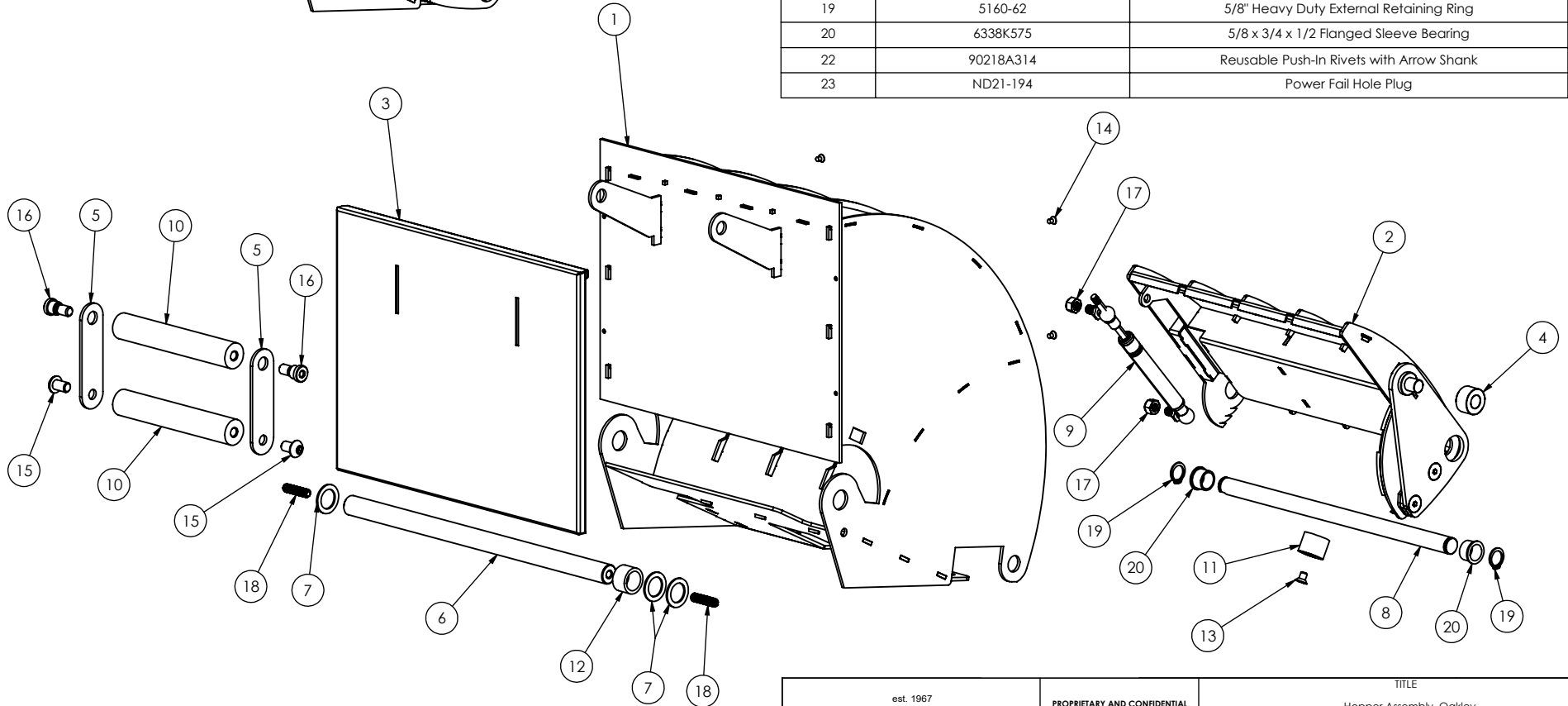

est. 1967 <b>HAMILTON</b> CUSTOM MADE SECURITY	PROPRIETARY AND CONFIDENTIAL THESE DRAWINGS ARE THE PROPERTY OF HAMILTON SAFE CO. AND SHALL NOT BE REPRODUCED, COPIED, USED AS THE BASIS FOR MANUFACTURE OR SALE OF APPARATUS WITHOUT PERMISSION		TITLE Hopper Assembly, Oakley	
	PART NUMBER OAK-HOPPER		DRAWN BY BilDef	
DATE 6/16/2022		CHECKED BY DATE		REVISION

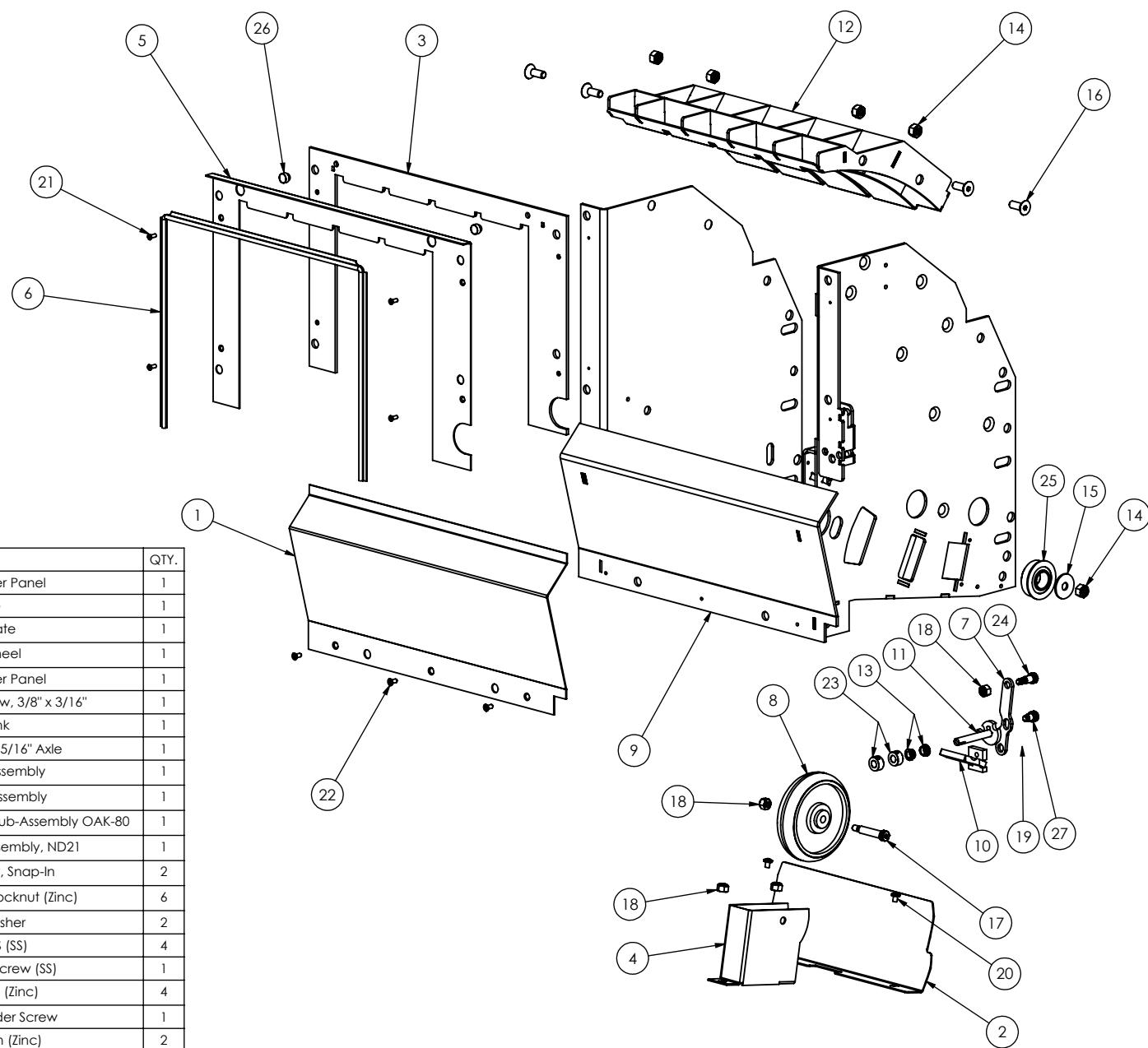

ITEM NO.	PartNo	DESCRIPTION	QTY.
1	ND21-025	Face, Bulkhead Center Panel	1
2	ND21-026	Deflector Plate	1
3	ND21-032	Bulkhead, Top Plate	1
4	ND21-050	Mount, Ejector Wheel	1
5	ND21-060	Face, Bulkhead Center Panel	1
6	ND21-090	1129A991 Rubber Seal, Hollow, 3/8" x 3/16"	1
7	ND21-114	Lock Acuator Link	1
8	ND21-154	4" x 1" Rubber Wheel For 5/16" Axle	1
9	OAK-FRM-WSA	Frame Welded Sub-Assembly	1
10	ND21-LPIN-WSA	Locking Pin Welded Assembly	1
11	ND21-LSFT-WSA-80	Lock Bolt Cam and Shaft Welded Sub-Assembly OAK-80	1
12	ND21-STS-WSA	Top Sweep Welded Sub-Assembly, ND21	1
13	H1009	5/16" ID Shaft Grommet, Snap-In	2
14	NNE31C/Z	5/16-18 Steel Nylon-Insert Locknut (Zinc)	6
15	WFE31N/125Z	5/16" Wide Flat Washer	2
16	KCS31C87/S	5/16-18 x 7/8 SFHCS (SS)	4
17	KSS31R137/S	5/16" x 1-3/8" Shoulder Screw (SS)	1
18	NNE25C/Z	1/4-20 Nylon Locknut (Zinc)	4
19	KSS31R50	5/16 x 1/2 Socket Shoulder Screw	1
20	MXP10F25/Z	10-32 x 1/4 Phillips Pan (Zinc)	2
21	MXF6C37/Z	6-32 x 3/8 Phillips Flat Head MS (SS)	4
22	MXF8C37/UCS	8-32 x 3/8 Undercut Phillips Flat Head Stainless Steel	3
23	SC31/1	5/16" Shaft Collar (Zinc)	2
24	KSS31R37	5/16 x 3/8 Socket Shoulder Screw	1
25	6384K367	3/4"IDx1-5/8"OD Flanged Ball Bearing	2
26	9309K36	Tight-Grip Push-In Bumpers	2
27	94361A121	5/16 x 1/4 Short-Thread Shoulder Screw	1

est. 1967 <b>HAMILTON</b> CUSTOM MADE SECURITY	PROPRIETARY AND CONFIDENTIAL THESE DRAWINGS ARE THE PROPERTY OF HAMILTON SAFE CO. AND SHALL NOT BE REPRODUCED, COPIED, USED AS THE BASIS FOR MANUFACTURE OR SALE OF APPARATUS WITHOUT PERMISSION		TITLE Frame Assembly, Oakley		
	PART NUMBER OAK-FRAME		DRAWN BY BilDef		
		DATE 8/4/2022	CHECKED BY	DATE	REVISION

ITEM NO.	PartNo	DESCRIPTION	QTY.
1	ND21-006	Gate Guide Outer Track	1
2	ND21-099	Spacer, Gate Guide	4
3	ND21-143	Spacer Washer, Open Bumper	1
4	OAK-ASSIST	Assist Mechanism, Night Depository	1
5	OAK-DTNT	Detent Assembly, Oakley	1
6	OAK-FRM-WSA	Frame Welded Sub-Assembly	1
7	KFC31C62	5/16-18 x 5/8 SFHCS	6
8	KCS25C50/Z	1/4-20 x 1/2 SHCS	1
9	93115K221	Bumper, 1" x 3/4" High 1/4-20 Thread	1
10	8507K45	U-Channel Trim, 1/4" x 1/2" Inside, 2-1/2" Long	1
11	ND21-125	Lock Pin, ND21	1
12	ND21-126	Anchor Block, Lock Pin	1

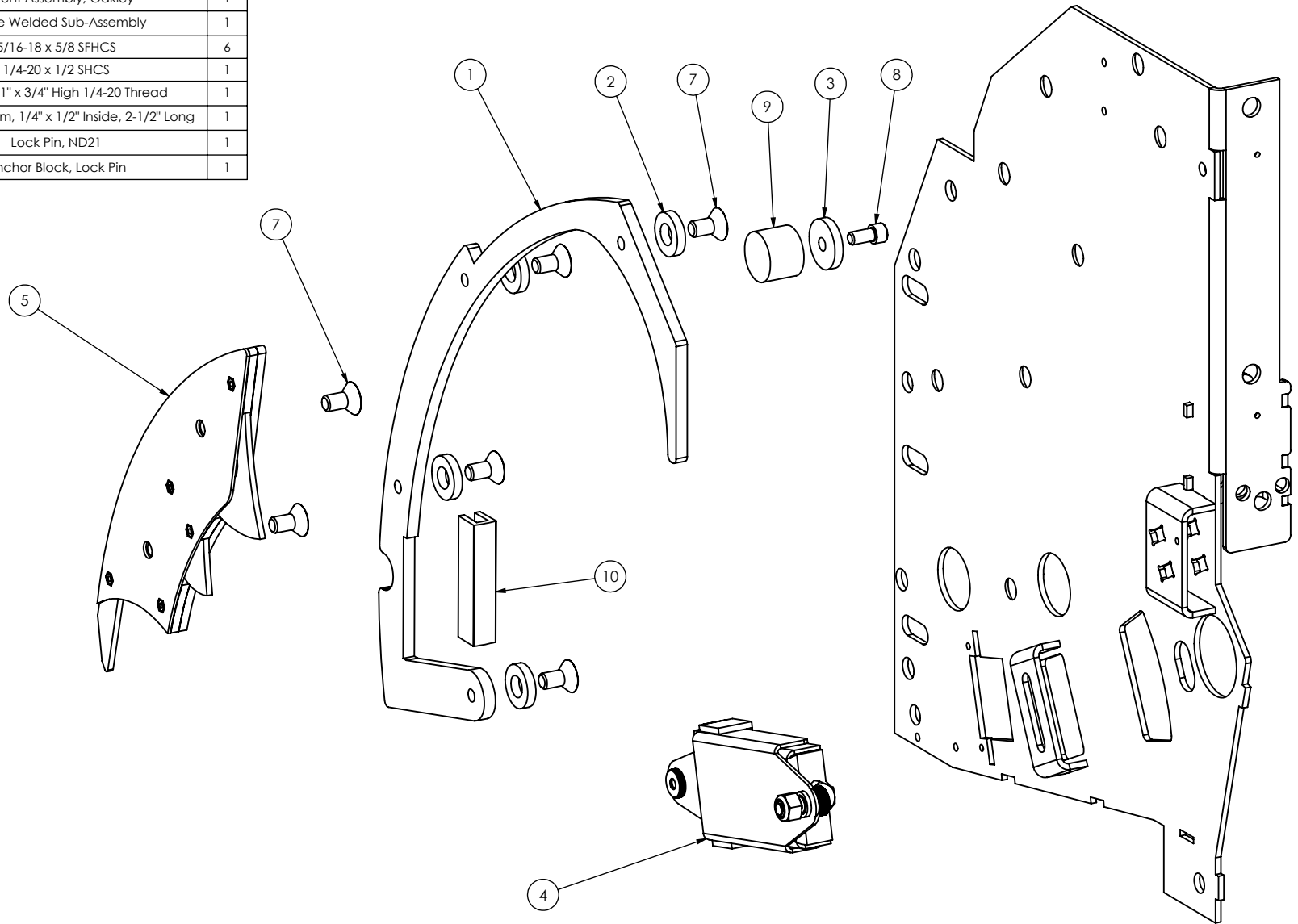

est. 1967 <b>HAMILTON</b> CUSTOM MADE SECURITY	PROPRIETARY AND CONFIDENTIAL THESE DRAWINGS ARE THE PROPERTY OF HAMILTON SAFE CO. AND SHALL NOT BE REPRODUCED, COPIED, USED AS THE BASIS FOR MANUFACTURE OR SALE OF APPARATUS WITHOUT PERMISSION		TITLE Inner Frame Assembly, Oakley	
	PART NUMBER OAK-IN-FRAME		DRAWN BY BilDef	DATE 8/4/2022
		DATE  	REVISION  	

ITEM NO.	PartNo	DESCRIPTION	QTY.
1	ND21-034	Detent Main Plate	1
2	ND21-035	Detent Mid Plate	1
3	ND21-033	Detent Cover Plate	1
4	ND21-103	Lever 1, Detent	1
5	ND21-102	Lever 2, Detent	1
6	ND21-036	Lever 2, Detent	1
7	MXF6C37/Z	6-32 x 3/8 Phillips Flat Head MS (SS)	4
8	WUS10N/Z	#10 (3/16) USS Flat Washer - Z	1

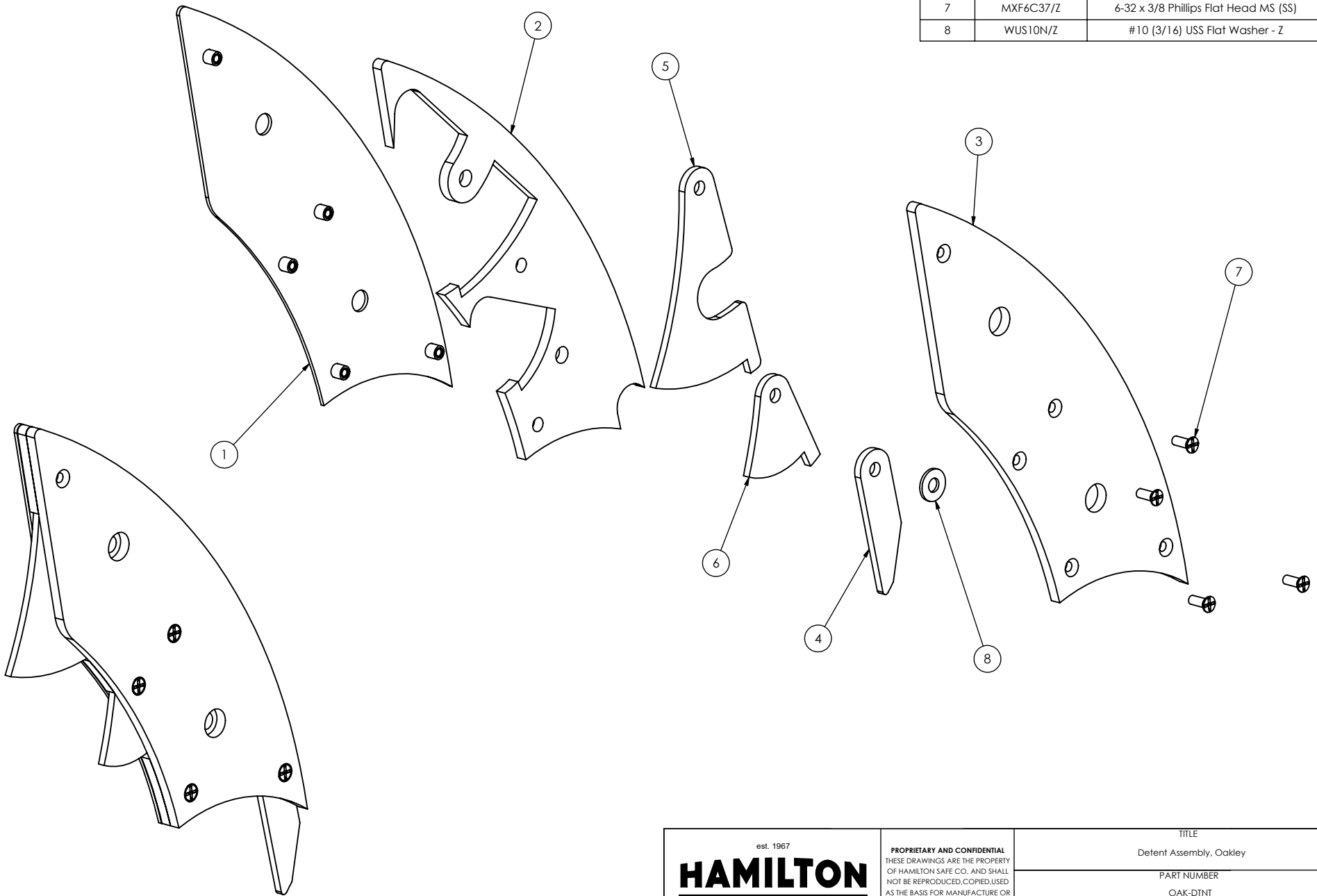

est. 1967 <b>HAMILTON</b> CUSTOM MADE SECURITY	PROPRIETARY AND CONFIDENTIAL THESE DRAWINGS ARE THE PROPERTY OF HAMILTON SAFE CO. AND SHALL NOT BE REPRODUCED, COPIED, USED AS THE BASIS FOR MANUFACTURE OR SALE OF APPARATUS WITHOUT PERMISSION		TITLE Detent Assembly, Oakley	
	PART NUMBER OAK-DTNT		REVISION A	
DRAWN BY BilDet	DATE	CHECKED BY	DATE	REVISION A

ITEM NO.	PartNo	DESCRIPTION	QTY.
1	ND21-073	Main Support Bracket, Sib Assist	1
2	ND21-ASST-WSA	Assist Support Bracket Welded Sub-Assembly	1
3	ND21-156	Blue Chrome-Silicon Steel Die Spring	1
4	NFJ37C/Z	3/8-16 Hex Jam Nut (Zinc)	3
5	WUS31N/Z	5/16" Flat Washer	1
6	ND21-167	Detent Spring Alignment Bolt	1

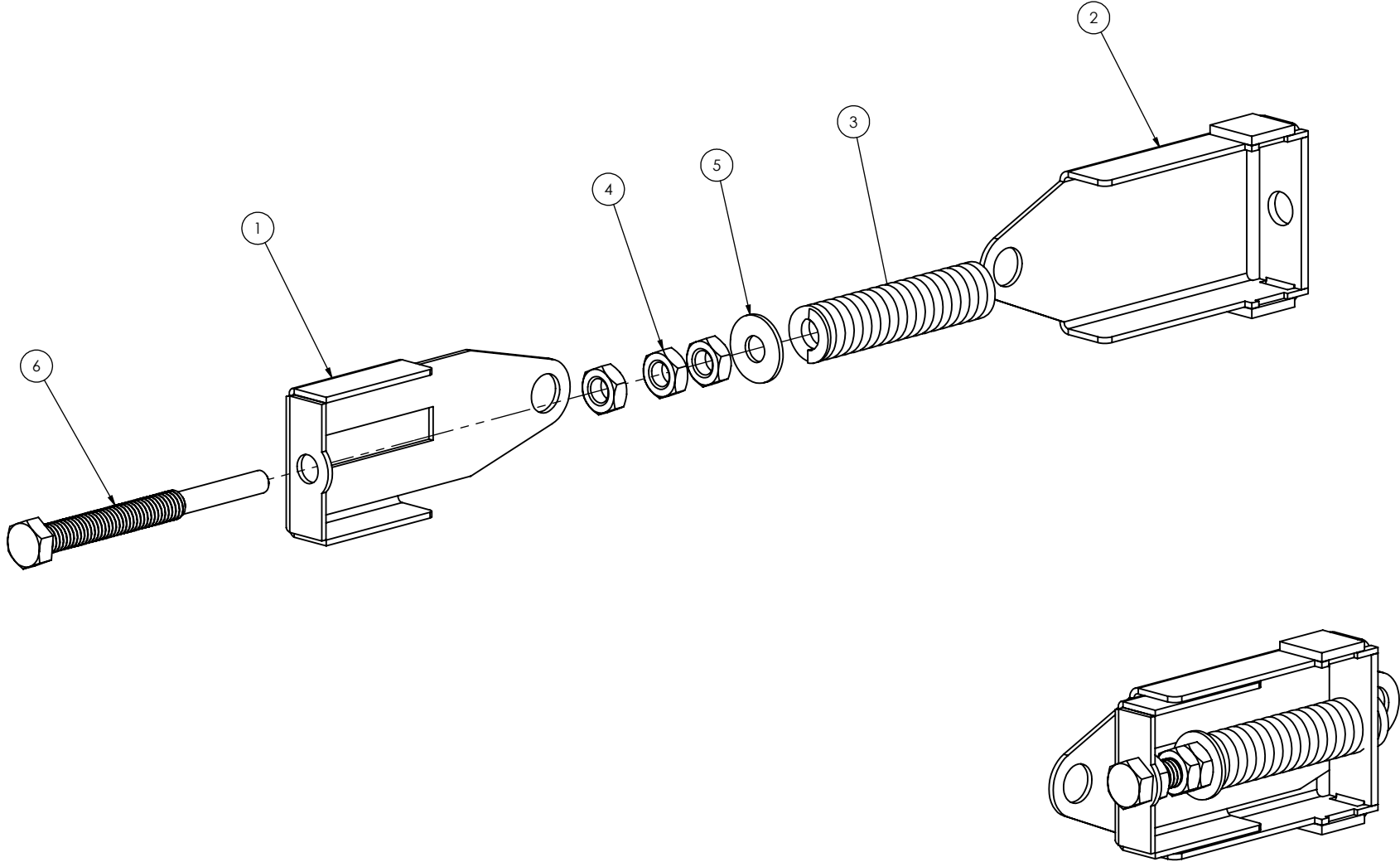

est. 1967 <b>HAMILTON</b> CUSTOM MADE SECURITY	PROPRIETARY AND CONFIDENTIAL THESE DRAWINGS ARE THE PROPERTY OF HAMILTON SAFE CO. AND SHALL NOT BE REPRODUCED, COPIED, USED AS THE BASIS FOR MANUFACTURE OR SALE OF APPARATUS WITHOUT PERMISSION		TITLE Assist Assembly, Oakley	
	PART NUMBER OAK-ASSIST		DRAWN BY BilDet	DATE 9/22/2022
		DATE  	REVISION  	

ITEM NO.	PartNo	DESCRIPTION	QTY.
1	ND21-040	Right Side Panel, NEW Face	1
2	ND21-041	Bottom Panel, NEW Face	1
3	ND21-042	Support Frame, NEW Face	1
4	ND21-043	Face, Upper Center Envelope Storage	1
5	ND21-044	Box, Envelope Storage	1
6	ND21-045	Left Side Panel, NEW Face	1
7	ND21-083	Side Support Channel, Lock	1
8	ND21-084	Side Support Channel	1
9	ND21-085	Bottom Support Channel	1
10	ND21-106	Lock Cylinder Retainer Bracket	1
11	ND21-107	Flap, Envelope	1
12	ND21-181	Camera Mounting Bracket, ND21 Covert	1
13	ND21-188	Side Support Channel, Housing New Install	2
14	WUS25N/Z	1/4" Flat Washer (Zinc)	11

ITEM NO.	PartNo	DESCRIPTION	QTY.
15	NNE25C/Z	1/4-20 Nylon Locknut (Zinc)	11
16	MXP10F75/S	10-32 x 3/4 Phillips Pan (SS)	2
17	MXP10F50/Z	10-32 x 1/2 Phillips Pan (Zinc)	4
18	NME10F/Z	10-32 Hex Nylon Lock Nut	4
19	KBC10F50/TPS	10-32 x 1/2 SBHCS (SS)	10
20	HCS37C100/5Z	3/8-16 x 1 HHMS (Zinc)	6
21	NNE37C/Z	3/8"-16 Nylon-Insert Locknut	18
22	7075YA1026DKD	Key Cylinder, Depository	1
23	HCS75C250/5Z	3/4-10 x 2-1/2 HHMS (Zinc)	1
24	HCS37C75/5Z	3/8-16 x 3/4 HHMS (Zinc)	12
25	LMS75N/Z	3/4" Split Lock Washer (Zinc)	1
26	NFH75C/Z	3/4-10 Hex Nut (Zinc)	1
28	ND21-ANCR-WSA	Anchor Plate, Welded Sub-Assembly	1

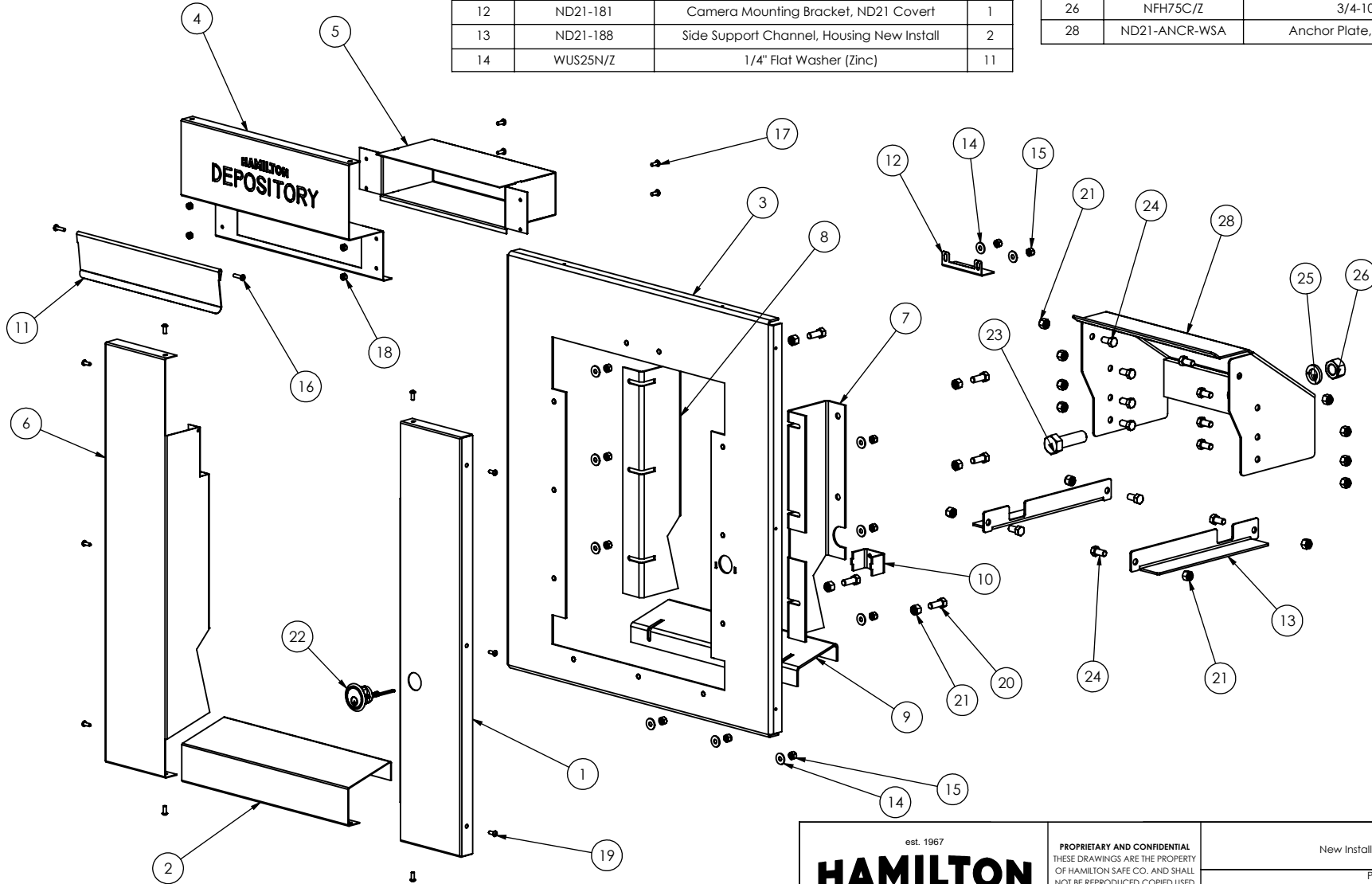

est. 1967  
**HAMILTON**  
 CUSTOM MADE SECURITY

PROPRIETARY AND CONFIDENTIAL  
 THESE DRAWINGS ARE THE PROPERTY  
 OF HAMILTON SAFE CO. AND SHALL  
 NOT BE REPRODUCED, COPIED, USED  
 AS THE BASIS FOR MANUFACTURE OR  
 SALE OF APPARATUS WITHOUT  
 PERMISSION

TITLE			
New Installation Assembly, OAK-80			
PART NUMBER			
OAK-80			
DRAWN BY	DATE	CHECKED BY	DATE
BlDef	12/2/2022		
REVISION			