

	Part Number	Description	QTY.
1	OAK-T-10	OAK-T Mounting Bracket	1
2	OAK20	Oakley Night Depository Head, 20" Flat Face	1
3	OAK-T-11	OAK-T Ramp	1
4	OAK-T-08	Cover Pan	1
5	OAK-T-09	SS Fascia	1
6	H0504	3/8-16 x 1 SHCS	8
7	H0294	.375" SPLIT LOCKWASHER	8
8	H0293	3/8 Flat Washer	8
9	H0564	#10 Fender Washer	6
10	H10211	#10 Phil FHMS	6
11	OAK-FLEX-29	29" Long Extended Flex Chute Kit	1

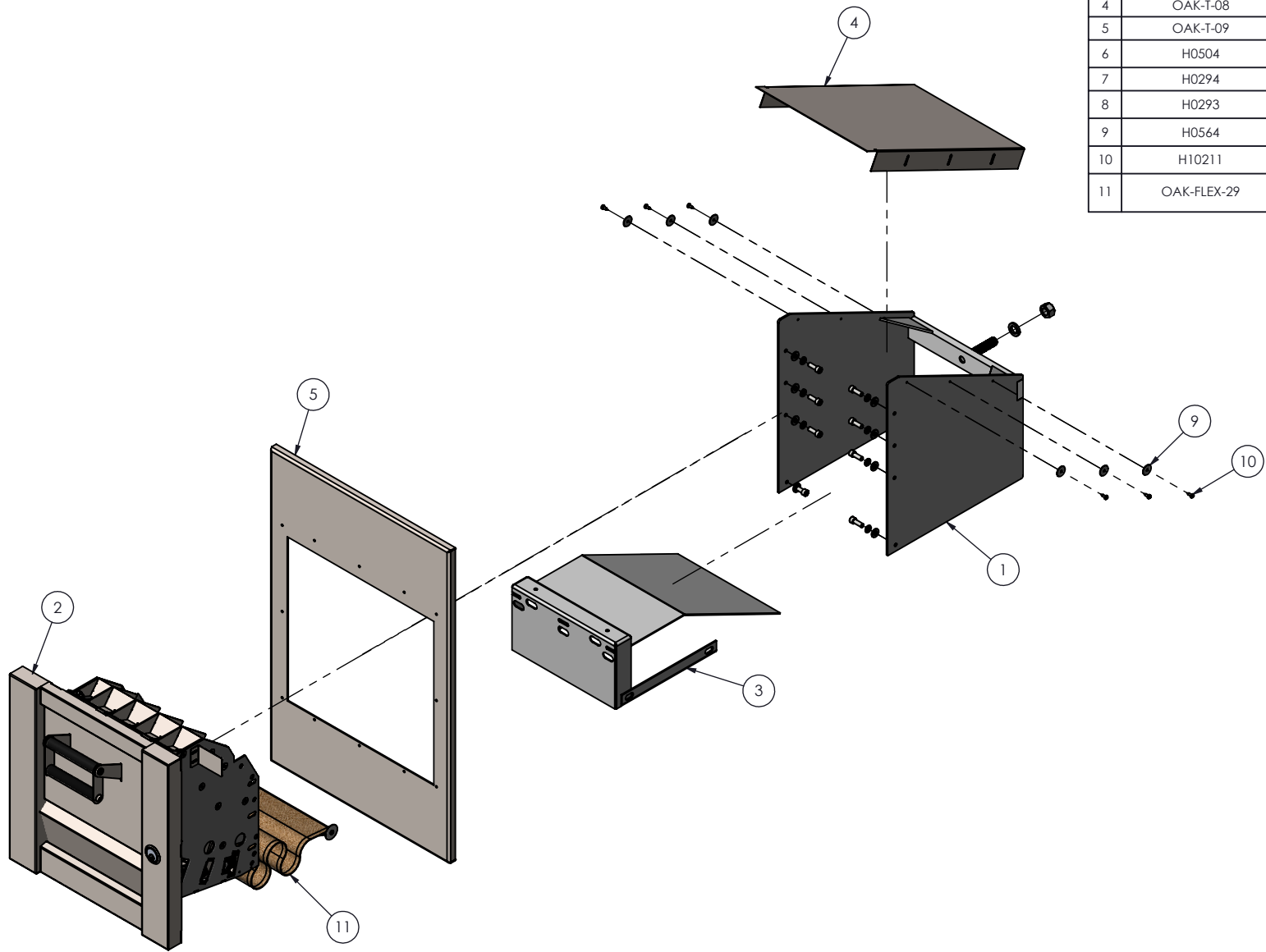

	PROPRIETARY AND CONFIDENTIAL THESE DRAWINGS ARE THE PROPERTY OF HAMILTON AND SHALL NOT BE REPRODUCED, COPIED, USED AS THE BASIS FOR MANUFACTURE OR SALE OF APPARATUS WITHOUT PERMISSION		TITLE OAK20 "T" Replacement Kit	
	PART NUMBER 96-798_OAK20-T Kit		FINISH	
	All Weld Notes Comply With AWS A2.4-98 Standards	DRAWN BY TerStr	DATE CHECKED BY 3/18/2024	DATE