

HAMILTON

TECHNICAL BULLETIN

Support Number: 513-874-3733
Fax: 513-874-6232
Web Site: www.hamiltonsafe.com
Email: support@hamiltonsafe.com

Author: Bill Detherage	Bulletin # SB-1008
Verification: Dion Cullum	Date Issued: 11/24/09
Product: HA45 & HA50	Date Revised:

Subject:
HA45 and HA50 Safety Bar

All Hamilton Dealers,

The HA45 and HA50 tube systems were recently revised to incorporate Hamilton's new I/O control board, a new designed removable turbine pack, and a safety bar along the top of the customer unit door. We have learned the safety bar may have potential to rub the screws and nuts used to mount the door trim located on the front stainless steel skin. If the safety bar becomes stuck, it will cause the system to stop functioning, but once the safety bar is released the system will operate again.

The safety bar issue can make the system appear to have intermittent electronic issues. The safety bar may be overlooked when a technician is servicing the units causing the issue to continue.

The safety bar should have $15/16$ " wide cut-outs on both sides as shown below to clear the hardware on the front skin. Check dimensions of the safety bar for accuracy, and if the safety bar is notched smaller than shown, it could possibly rub and stick on the front skin hardware. The safety bar part number is **B10166**.

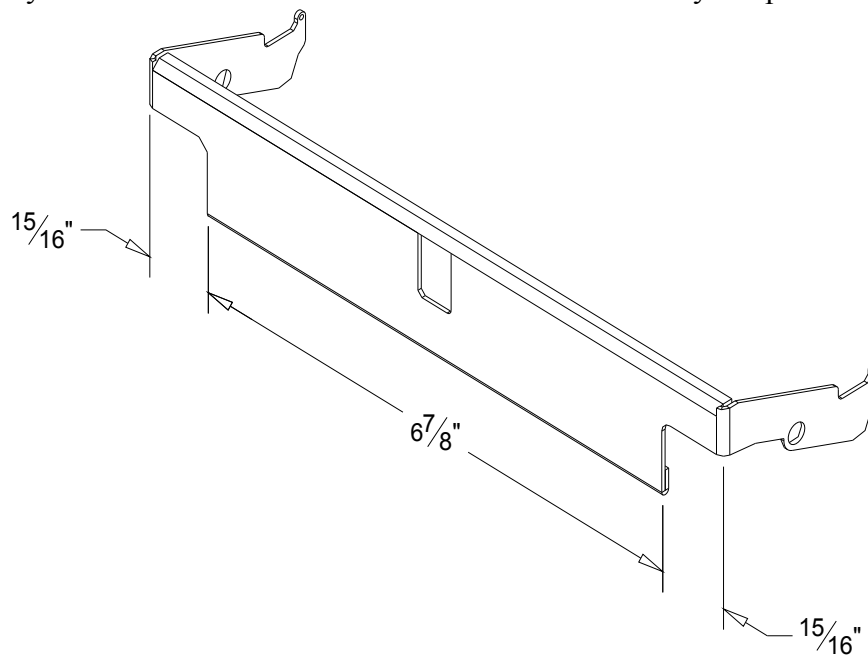

Note: This bulletin is only applicable to the HA45 and HA50 units with Hamilton's new I/O control board, a new designed removable turbine pack, and a safety bar along the top of the customer unit door.

Please call or email Hamilton Safe if you have any questions or concerns.

2/8/2012