

# **HAMILTON AIR®**

3143 Production Drive • Fairfield, Ohio 45014 • 513-874-3733

Model **HA-45** and **HA50**  
with I/O controls.  
Removable or remote turbine packs.

Installation and Service Manual

## **Important Notice:**

### **This Unit requires CAT5 interconnection**

Models that include the I/O control boards (E0873) are interconnected from customer to teller unit with a single **CAT5 cable** (Hamilton P/N E0889). This replaces the multi-conductor cable used on previous versions.

**Audio** connections remain similar to previous models requiring a separate multi-conductor cable (P/N E0680) connected between the customer unit and audio matrix.

### **Preoperational settings and inspections**

**\* The I/O control board requires jumpers and switches to be properly set before operation.**

**\* The customer unit requires the turbine power wire to be connected to the appropriate terminal.**

**NOTE:** All **Micro-Switches** should be inspected for proper adjustment and operation by manually moving the door and safety bar before operating unit. Switches should be set to allow for variations in the set-points due to temperature changes and/or vibrations. This will insure that all adjustments and operations are satisfactory.

## HA45 / HA50 Turbine Power Wire Connection

The unit is shipped with the **RED** main turbine power wire connected to terminal #4 ready for turbine pack to be mounted inside customer unit. If the system will use the remotely mounted turbine pack, the **RED** main turbine power wire must be moved to terminal #5. Connection must be made during installation for the unit to operate properly. The **RED** main turbine power wire is located below the I/O control panel on the main terminal strip. The wire can be connected to either terminal #4 or #5 depending on your configuration.

The configurations are based on the location and type of the turbine package. The turbine can be mounted within the customer unit (HA45) or remotely mounted outside of the customer unit (HA50).

The turbine package mounted within the customer unit connects directly to the terminal strip below the I/O control board. This requires the **RED** turbine power wire to be connected to 120 volts AC on terminal #4.

The turbine package mounted outside of the customer unit will be supplied 120 volts AC from the building power panel. The turbine will connect to the customer unit with low voltage cable to trigger the turbine relays. This configuration requires the **RED** turbine power wire to connect to 24 volts AC on terminal #5.

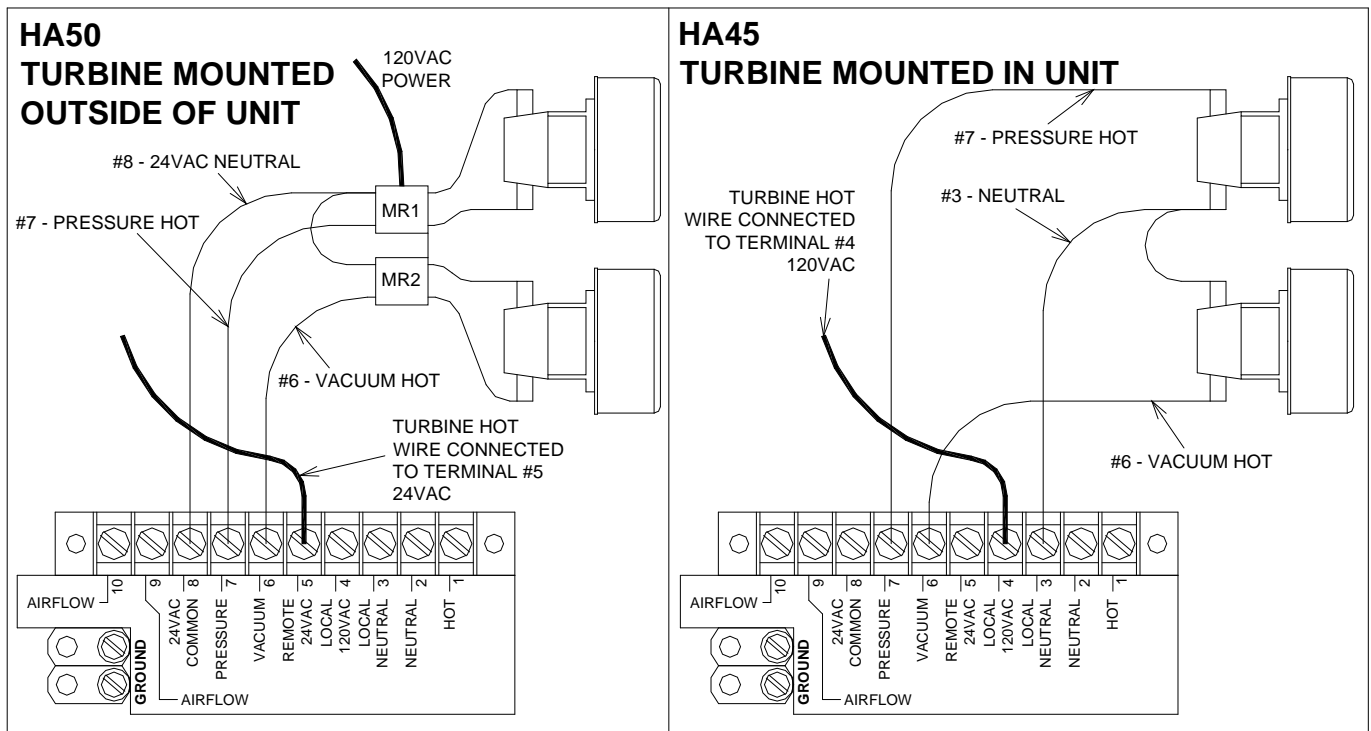

Note: Terminal #8 is 24VAC common when turbines are mounted remotely. When the turbine package is mounted within the customer unit, terminal #3 is typically the neutral connections for the turbine motors unless an airflow kit has been added. The pressure turbine motor of a local turbine with airflow kit uses terminal #8 for neutral connection.

# HA45 NOTICE:

CHECK CARTON CAREFULLY FOR ALL COMPONENTS SHOWN BELOW

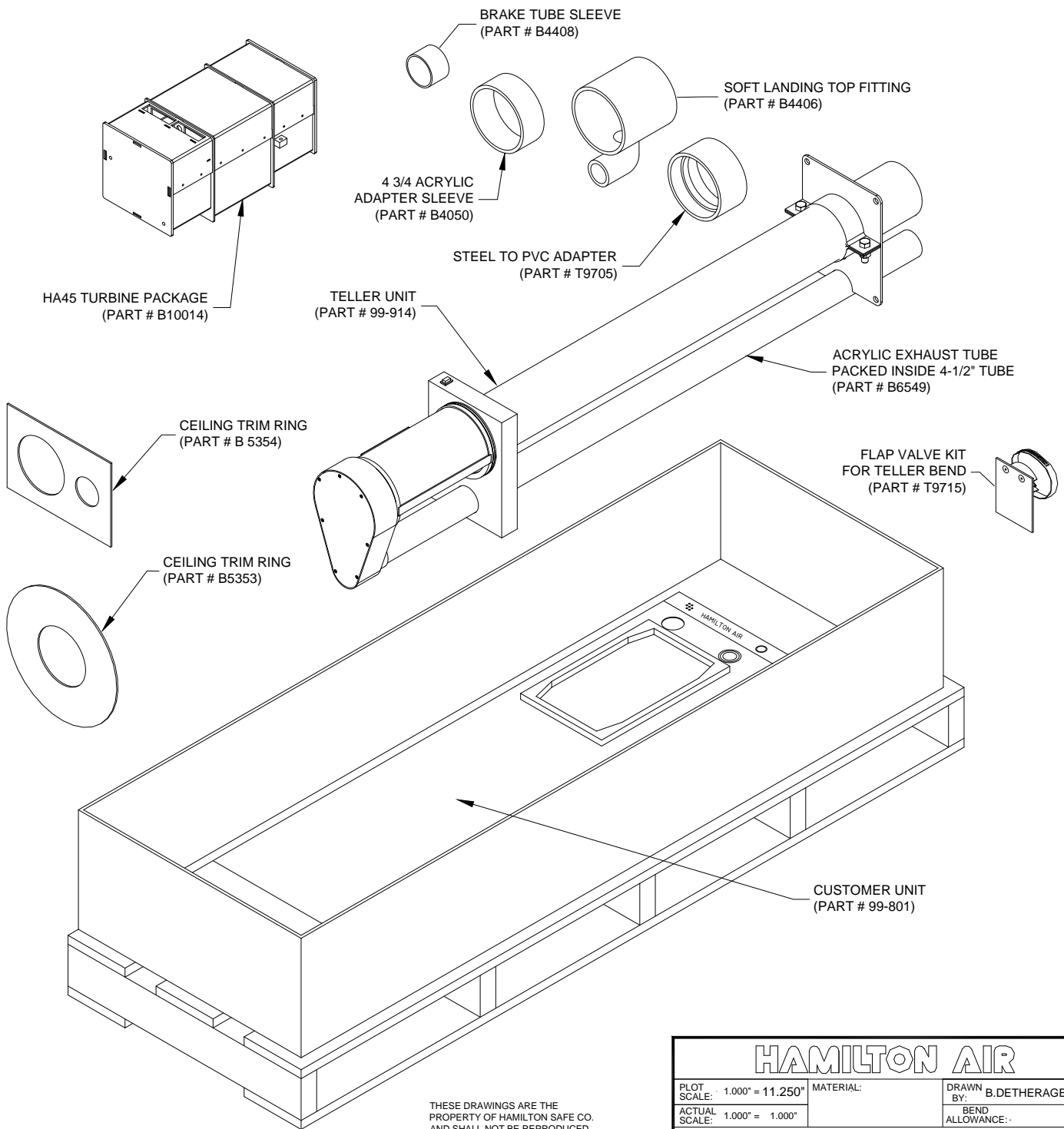

REVISION "A" 2/4/02 (CHANGED LAYOUT TO MATCH NEW CARTON FOR ALEX)  
 REVISION "B" 10/3/02 (ADDED EXHAUST MUFFLER PARTS TO DRAWING)  
 REVISION "C" 10/7/05 (UPDATED TO NEW STYLE STANDARD OVERHEAD TELLER)  
 REVISION "D" 6/24/09 (ADDED REMOVABLE TURBINE PACKAGE)  
 REVISION "E" 6/25/09 (ADDED T9715 TELLER FLAP VALVE KIT)

THESE DRAWINGS ARE THE PROPERTY OF HAMILTON SAFE CO. AND SHALL NOT BE REPRODUCED OR COPIED OR USED AS THE BASIS FOR MANUFACTURE OR SALE OF APPARATUS WITHOUT PERMISSION

TOLERANCES UNLESS OTHERWISE NOTED:  
 FRACTIONS:  $\pm 1/64"$   
 DECIMALS:  $\pm .005$   
 ANGLES:  $\pm 1/2^\circ$

<b>HAMILTON AIR</b>		
PLOT SCALE: 1.000" = 11.250"	MATERIAL:	DRAWN BY: B.DETHERAGE
ACTUAL SCALE: 1.000" = 1.000"		BEND ALLOWANCE:
TITLE: <b>HA45 SHIPPING CARTON</b>		
DATE:	DRAWING NUMBER: <b>HA45SC01</b>	REVISION: <b>E</b>

# HA50 NOTICE:

CHECK CARTON CAREFULLY FOR ALL COMPONENTS SHOWN BELOW

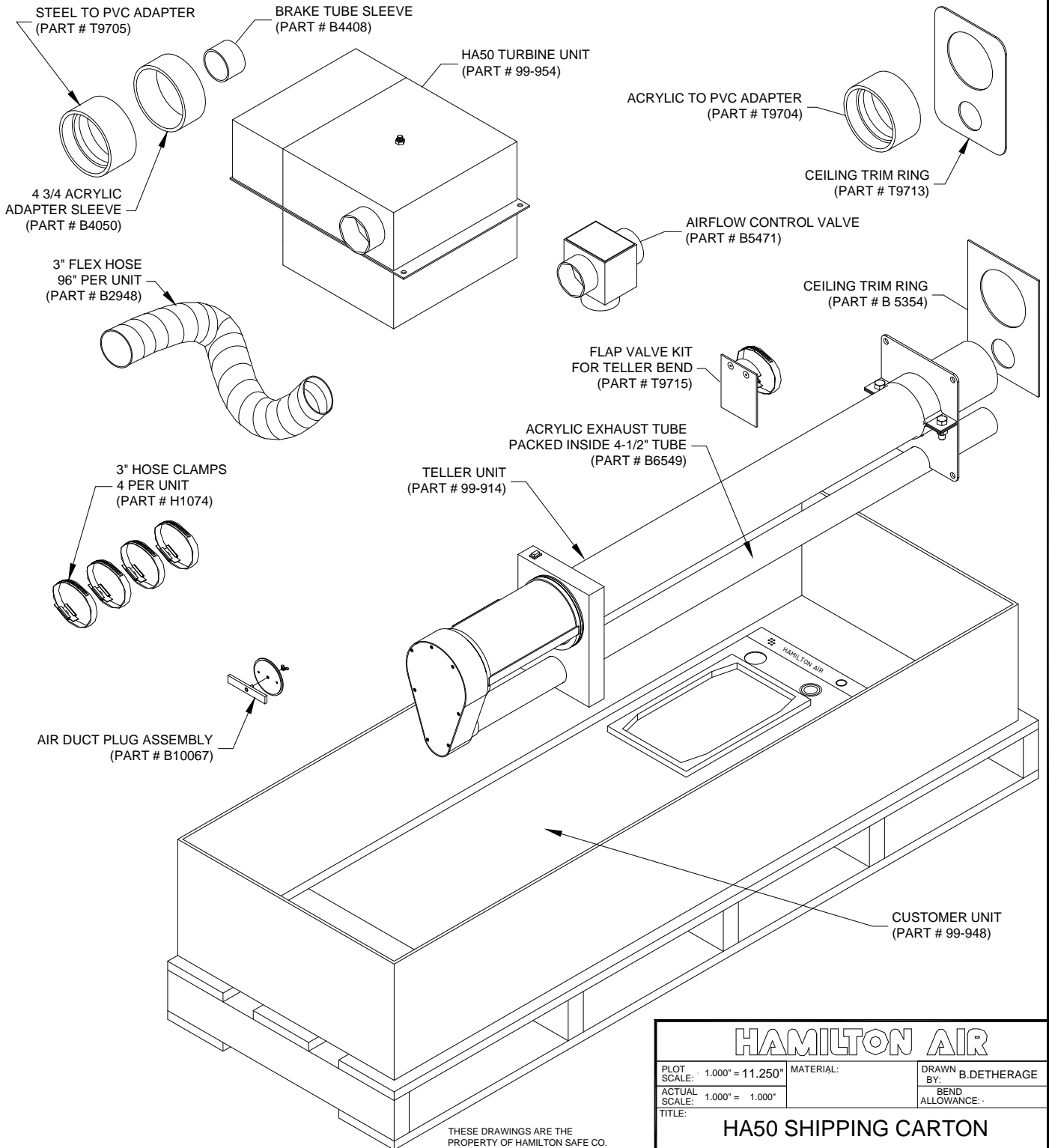

REVISION "A" 10/29/09 (ADDED B10067 AIR DUCT PLUG ASSEMBLY TO DRAWING)

THESE DRAWINGS ARE THE PROPERTY OF HAMILTON SAFE CO. AND SHALL NOT BE REPRODUCED OR COPIED OR USED AS THE BASIS FOR MANUFACTURE OR SALE OF APPARATUS WITHOUT PERMISSION

<b>HAMILTON AIR</b>		
PLOT SCALE: 1.000" = 11.250"	MATERIAL:	DRAWN BY: B.DETHERAGE
ACTUAL SCALE: 1.000" = 1.000"		BEND ALLOWANCE:
TITLE: <b>HA50 SHIPPING CARTON</b>		
DATE:	DRAWING NUMBER: <b>HA50SC01</b>	REVISION: <b>A</b>

## Switch Settings

The switches on the control boards are used to set functions and test operations. There are three slide switches and one pushbutton switch located on the control boards. The three slide switches are labeled #1, #2, and #3 while the fourth pushbutton switch (SW4) is labeled “Carrier Recall”. Momentarily pressing SW4 recalls the carrier to this end of the tube system.

### Standard switch settings for Customer mounted control board

- SW1            Switch 1: **Blower Run Time Set.** “Off” is normal setting. Switching “On” enables blower “Time-Set” mode. See “Blower Run Time Set” for full instructions on setting blower run times.
- Activate “Turbine Test Mode” by holding SW4 while switching SW1 “On” if customer door is open and turbines are connected to this control board. Send and teller call will activate the pressure and vacuum turbines.
  - If SW3 is turned on before SW1, the unit will enter “Door Test Mode” which allows send and teller call buttons to operate the customer door motor open and closed.
- SW2            Switch 2: **Turbine Mode.** “Off” is normal setting with single stage turbine. “On” is normal setting with multi-blower turbine systems.
- SW3            Switch 3: **Unit Selection.** “Off” is normal setting for board mounted in customer unit.

### Standard switch settings for Teller mounted control board

- SW1            Switch 1: **Diagnostic Mode.** “Off” is normal setting. Switching “On” enables “Door Test Mode” which allows send and recall buttons to operate the teller door motor open and closed.
- Activate “Turbine Test Mode” by holding SW4 while switching SW1 “On” if teller door is open and turbines are connected to this control board. Send and recall will activate the pressure and vacuum turbines.
- SW2            Switch 2: **Turbine Mode.** “Off” is normal setting.
- “On” is normal setting for CM2 teller only.
- SW3            Switch 3: **Unit Selection.** This switch has been removed and permanently fixed in the “On” position.

# Interconnection Cable

## CAT5 Interconnect Cable Wiring

The I/O control board system requires an interconnect cable to connect the manual teller unit to the control board located in the customer unit and/or the control board located in the teller unit to the control board located in the customer unit. This cable is a standard category 5 (CAT5) cable, Hamilton part number E0889, and terminated with male RJ-45 connectors on both ends. The connectors should be wired in the straight through design as shown below on both ends. There are commercially available testers that can be used to verify correct connector installation and function.

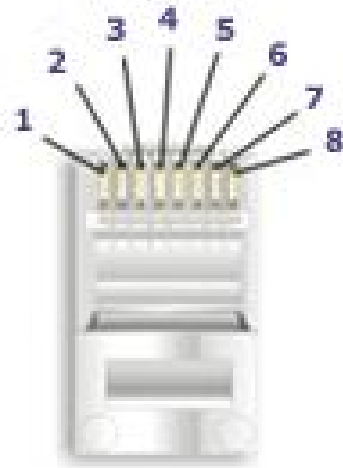

Wire	Pin #	Teller Connections
White/Orange	1	Spare
Orange	2	Teller Nigh Lock
White/Green	3	Teller Carrier Arrival
Blue	4	Teller Recall
White/Blue	5	Door Closed / Teller Send
Green	6	Common
White/Brown	7	RS485 A
Brown	8	RS485 B

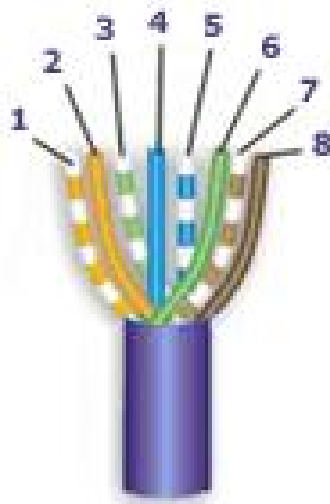

## **Additional Functions of E0873**

### **Door Auto-Close Option**

There is a fourth jumper that can be placed across pins #1 and #2 on the J4 input connector that will enable the door auto-close feature. This optional feature when activated by this jumper closes the customer door after three minutes of no activity with the unit. After the door has auto-closed, pressing either the send or teller call buttons will re-open the door for the customers.

### **Microphone Muting:**

The E0873 control board can be set-up to mute the microphone during blower operation with certain systems that have the blowers located close to the microphone in the customer unit. The control board can also be set-up not to mute the customer microphone during blower operation for systems that are not affected by the blowers.

- 1) Recall carrier to customer unit. (Press SW4 “Recall” located on control board)
- 2) Press and hold SW4 and press the teller call button on customer unit. The output LED for microphone mute will flash.

One flash = the microphone is set to mute.

Two flashes = the microphone is set to NOT mute.

- (Note: the input LED for the teller call button will light when the button is pressed. This is NOT the output LED for microphone mute and therefore NOT the LED that will signal the setting of microphone muting.)
- 3) Repeat step #3 to toggle between settings as needed.
    - (Note: SW4 and teller call must be released to toggle setting.)
  - 4) System is now functional as normal with the new setting for muting the microphone.



## Night Lock Switch on Over Head Teller

### **Night lock operation.**

The night lock function is used to turn the lane off for the night or whenever the lane will not be used. The night lock function will close the customer unit and call the carrier inside, if needed, to prevent outside use of the lane. If there is a video monitor connected to the control circuit using Hamilton cable #E10036, the night lock function will also turn the video monitor off for this lane. Note, if multiple lanes are installed, each lane will have its own separate night lock switch.

Night lock switch  
located under recall button.



The night lock switch is shown pushed to the back which is the normal run position.

Pulling the switch forward will put the lane in the night lock mode.

# Video Power Control

**Note, Only used with Hamilton 5517 two-way video units.**

## **E10036 Video Power Control Cable Installation**

Used only for 5517 video units when pneumatic tube system uses E0873-C I/O control boards.

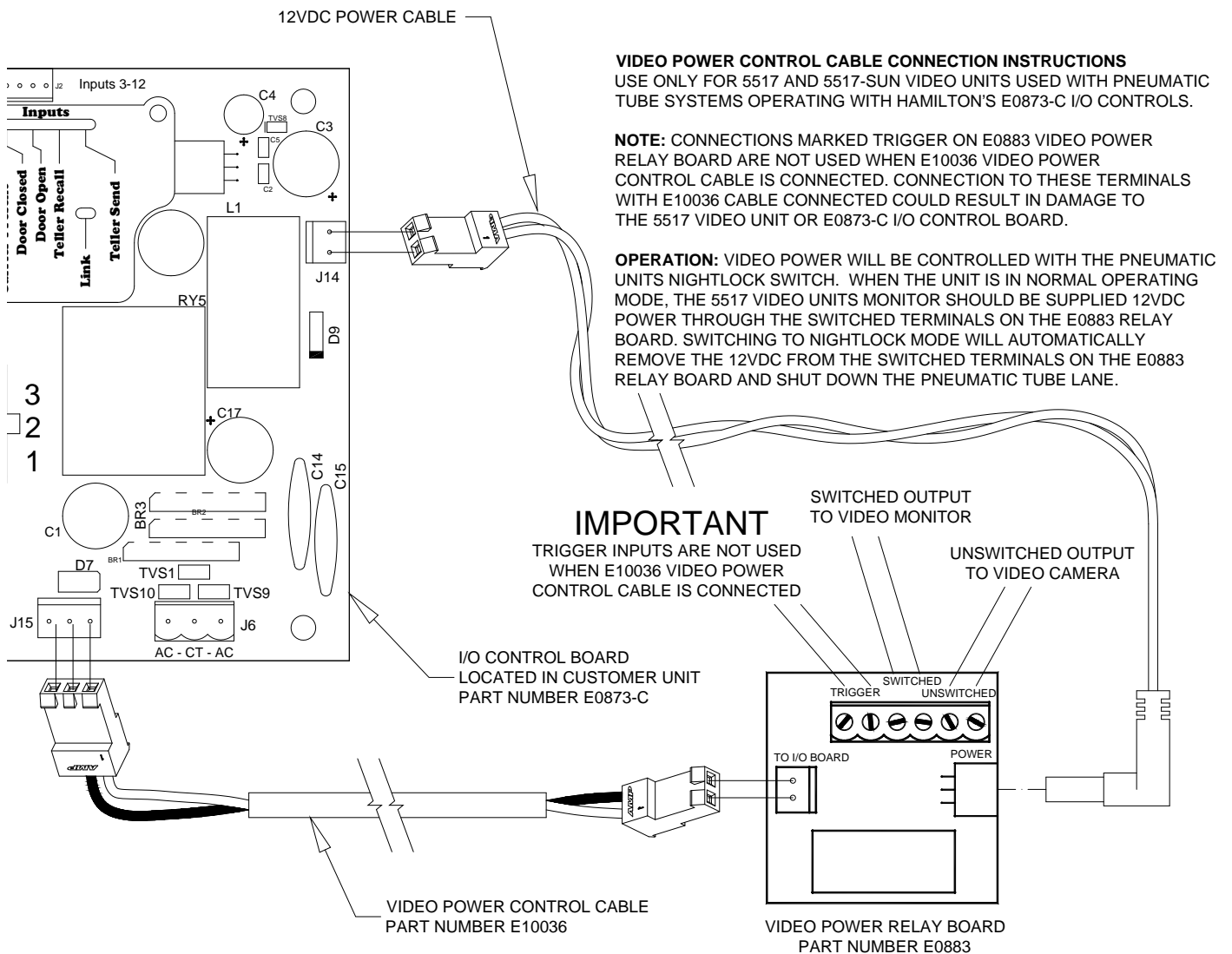

## **Blower Run-Time Set Procedure**

The “blower run time” is set using switch number one (SW1), which is located on the control board in the customer unit. The unit is shipped with a default time stored of about 3 seconds. This procedure will overwrite any existing times set in system. This time can be reset as often as necessary. **Power failure will NOT affect the times stored.**

### **To restore default blower run times:**

- 1) Turn power “OFF” to unit.
- 2) Turn SW1 “ON”.
- 3) Turn power “ON” to unit.
- 4) Wait 10 Seconds for unit to initialize.
- 5) Return SW1 to “OFF”.
- 6) Default blower run time is restored.

The blower run time can be set with both directions of carrier travel using the same time or in a three stage cycle. The three stage cycle includes individual times for the two directions of carrier travel along with a third time for the carrier to free fall in the clear acrylic tube after the blowers stop and before the customer door opens.

### **Setting procedure for blower run time. (Single time for both directions)**

- 1) Restore default times as described above.
- 2) Before beginning, the carrier must be in customer unit with customer door open.
- 3) Turn SW1 to the “ON” position. (LED indicator will light)
- 4) Push and hold either “Customer Send” or “Teller Recall” button until carrier arrives in the teller unit. Releasing button stores the time for this cycle.
  - Note:** For systems with carrier arrival switches at both ends, when the carrier arrives at the teller unit and activates the carrier arrival switch, the blowers will automatically turn off.
- 5) Turn SW1 to the “OFF” position to store the cycle time for both directions.
  - Note:** For systems with carrier arrival switches at both ends, the system will now run until it arrives and activates the carrier arrival switches at both customer and teller.

### **Setting procedure for blower run time. (Three stage cycle time)**

- 1) Before beginning, the carrier must be in customer unit with customer door open.
- 2) Turn SW1 to the “ON” position. (LED indicator will light)
- 3) Push and hold either “Customer Send” or “Teller Recall” button until carrier arrives in the teller unit. Releasing button stores the time for this cycle.
- 4) Push and hold either “Teller Send” or “Teller Call” button until carrier arrives in the clear acrylic tube on the customer unit. Releasing the button stores the time held for this cycle. (Turbines will shut off, customer door stays closed)
- 5) When carrier lands in customer unit, press and release “Teller Call” button to open the door. This stores a third time for carrier free fall time in the clear acrylic tubing. Turn SW1 to the “Off” position for normal operation.

## **Blower Run Time Set with CM2 Motorized Teller Unit**

The CM2 teller unit has a pressure switch that will act like a carrier arrival switch turning off the turbine motors. The pressure switch should be activated after the carrier passes the air relief valve in the teller bend turning off the turbines. The platform will remain closed until the carrier lands and the pressure is equalized releasing the pressure switch. This action is to ensure the platform does not open while the carrier is falling in the tube.

The “blower run time” is set using switch number one (SW1), which is located on the control board in the customer unit. The unit is shipped with a default time stored of about 3 seconds. This procedure will overwrite any existing times set in system. This time can be reset as often as necessary. **Power failure will NOT affect the times stored.**

### **Setting procedure for blower run time with CM2 Motorized Teller Unit.**

- 1) Restore default times as described above.
- 2) Before beginning, the carrier must be in customer unit with customer door open.
- 3) Turn SW1 to the “ON” position. (LED indicator will light)
- 4) Push and hold the “Customer Send” button until carrier arrives in the teller unit. The carrier will activate the carrier arrival switch, and the blowers will automatically turn off.
- 5) Wait for the teller platform to drop open with the carrier. This will happen after the carrier lands and pressure is equalized in the teller unit.
- 6) Push and hold the “Teller Call” button until carrier arrives in the clear acrylic tube on the customer unit. Releasing the button stores the time held for this carrier travel cycle. (Turbines will shut off when button is released, but the customer door will stay closed)
- 7) After carrier lands in customer unit, press and release “Teller Call” button to open the door. This stores a third time for carrier free fall time in the clear acrylic tubing.
- 8) Turn SW1 to the “Off” position for normal operation.

# Customer Control Board Connections

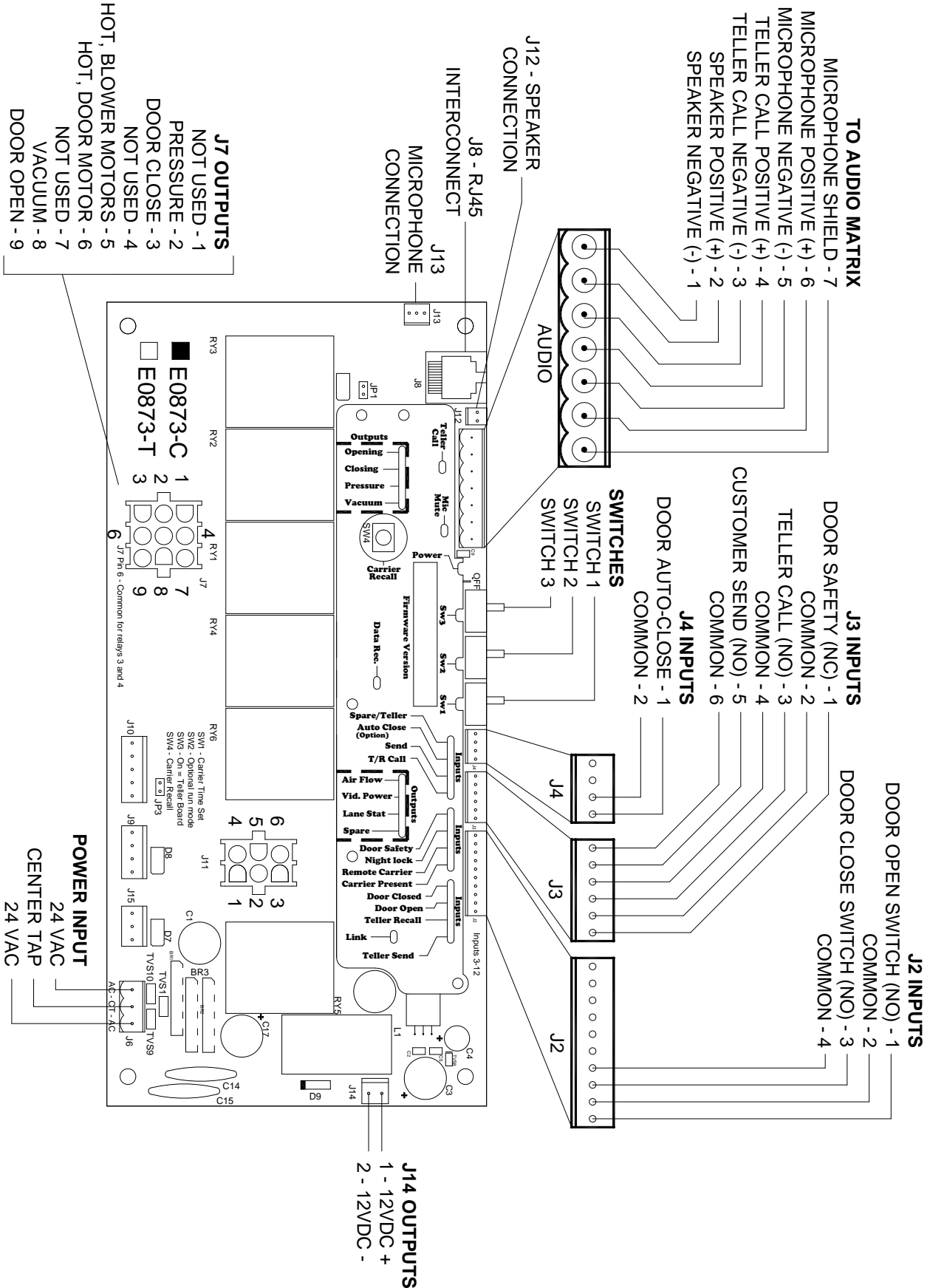

# Teller Control Board Connections (Not used with manual teller units)

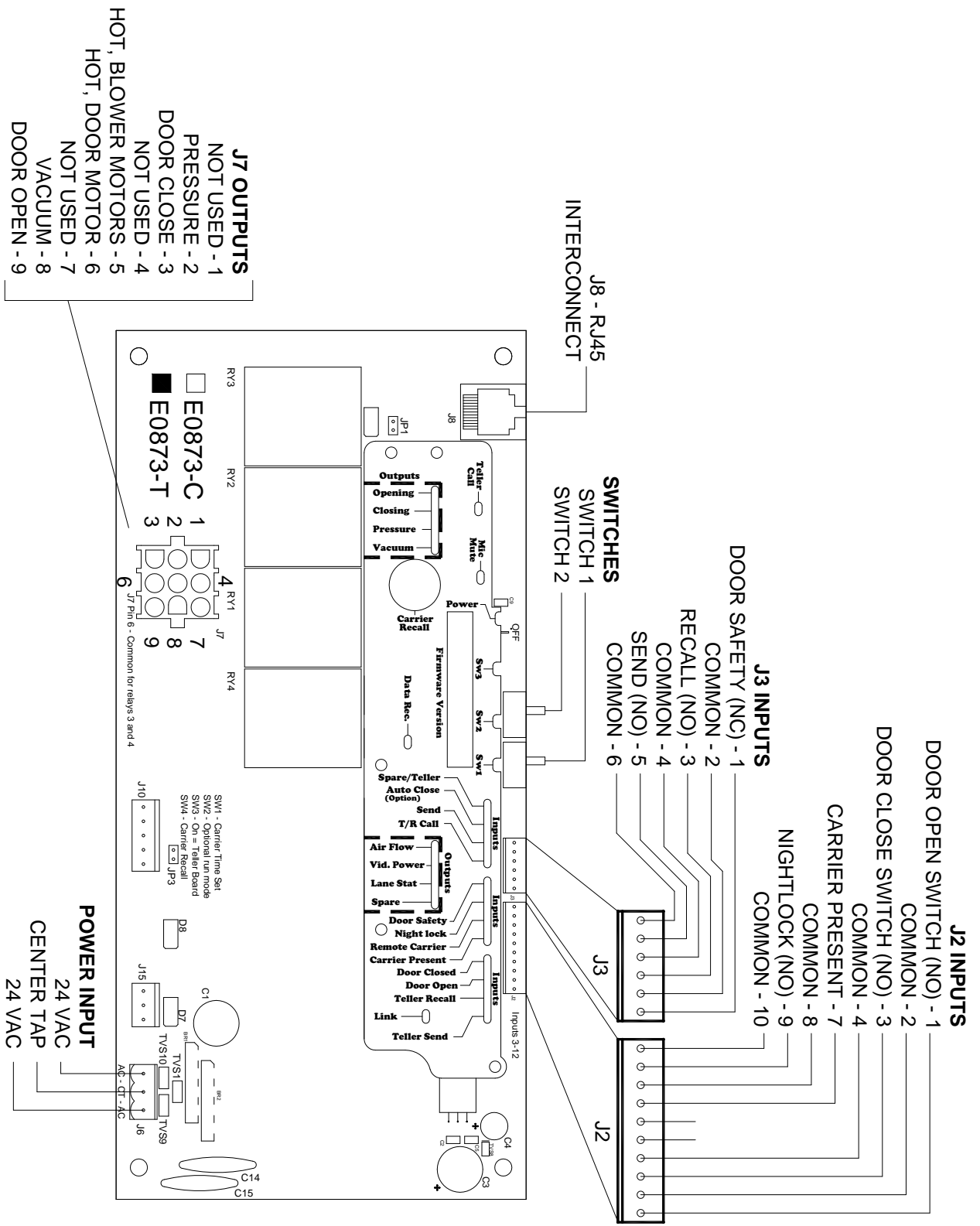

## **Troubleshooting the E0873**

### **Motorized Door Test (Automatic):**

- 1) Disconnect the interconnection cable from the board.
- 2) If the door is open, turn SW3 “ON”, if door is closed, turn SW3 “OFF”.
- 3) Cycle power “OFF” and back “ON”.
- 4) Door should open or close depending on the setting of SW3.
- 5) Repeat test in both directions and on both tube stations if applicable.

### **Motorized Door Test (Manual):**

- 1) Turn SW3 “ON” if not already “ON”
- 2) Turn SW1 “ON”
- 3) Send and Call or Recall activates the door manually. Releasing the button stops the door as well as tripping the limit switches.
- 4) Turn SW1 “OFF” and SW3 “OFF” for customer or “ON” for teller for normal operation.

### **Blower Run Test:**

- 1) Test is performed on terminal that turbines are controlled from. This could be on either customer or teller station on a two board system.
- 2) Recall carrier to station that has turbines connected so that door will open.
- 3) Hold SW4 while switching SW1 “ON”.
- 4) Pressing send and teller call or recall will activate the pressure and vacuum turbines.
- 5) Turn SW1 “OFF” to return to normal operation.

### **Restore Default Blower Run Times:**

- 1) Turn power “OFF” to unit.
- 2) Turn SW1 “ON”.
- 3) Turn power “ON” to unit.
- 4) Wait 10 Seconds for unit to initialize.
- 5) Return SW1 to “OFF”.
- 6) Default blower run time is restored.

# HA45 Turbine Pack Mounting and Connection

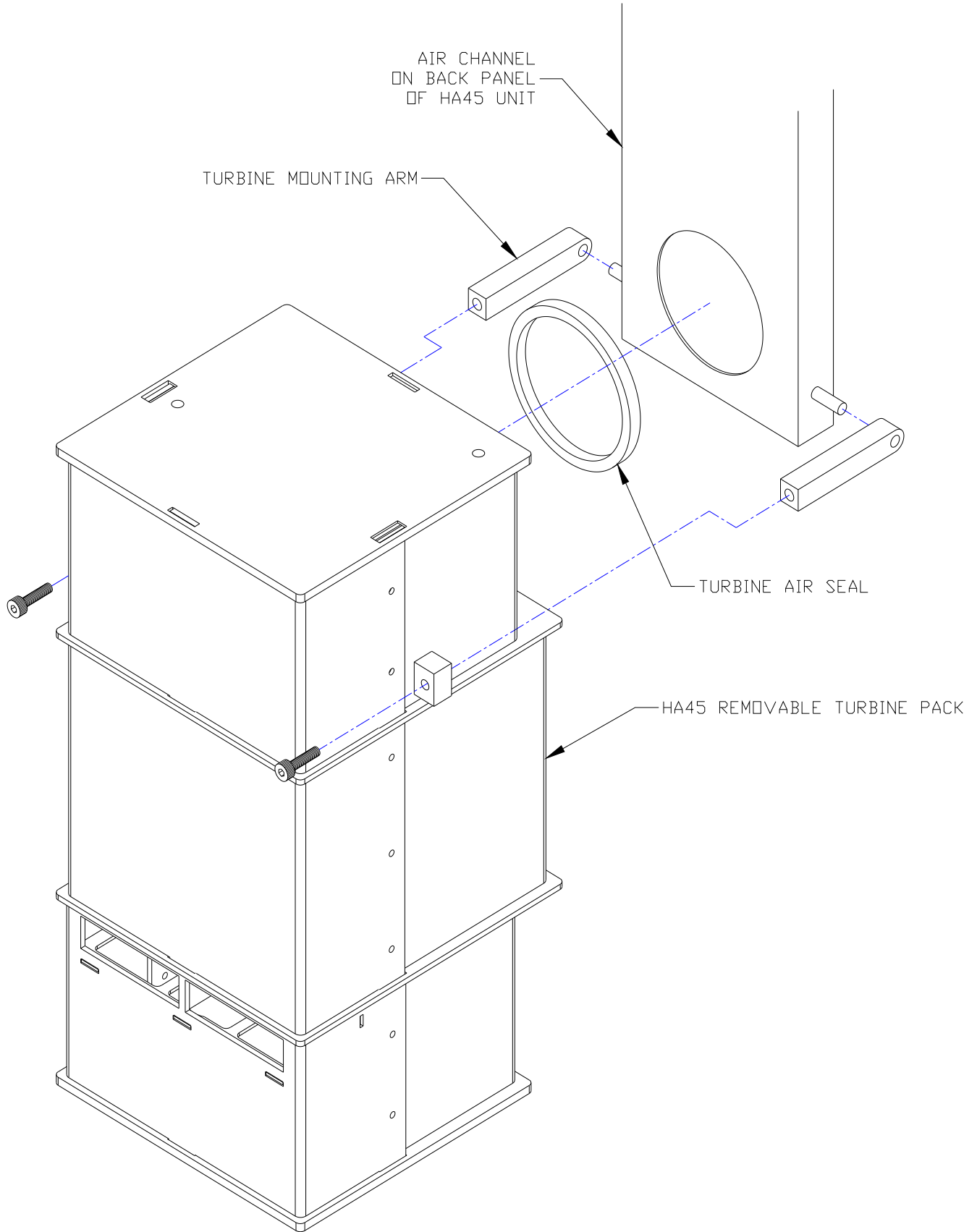



PVC BEND WITH 3" PORT  
PART NUMBER T9608

3" FLEX-HOSE (8FT INCLUDED PER LANE)  
PART NUMBER B2948  
(CONNECTION BETWEEN TURBINE AND VALVE  
CAN BE EXTENDED USING RIGID TUBING)

**NOTE:** TURBINE UNIT MUST BE SETTING  
FLAT ON ITS BOTTOM TO OPERATE PROPERLY.  
UNIT TOP VIEW SHOWN.

TURBINE CONNECTION PORT  
LOCATED ON THIS SIDE  
FOR CONNECTION TO SYSTEM

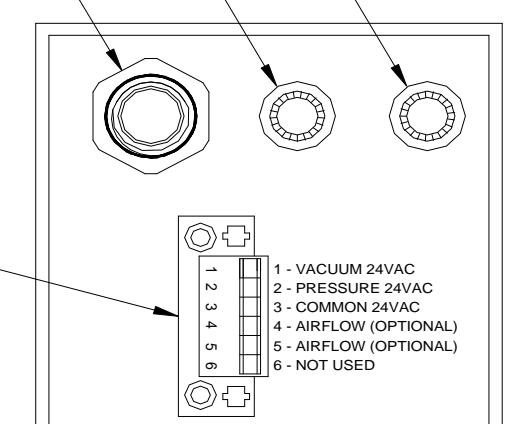
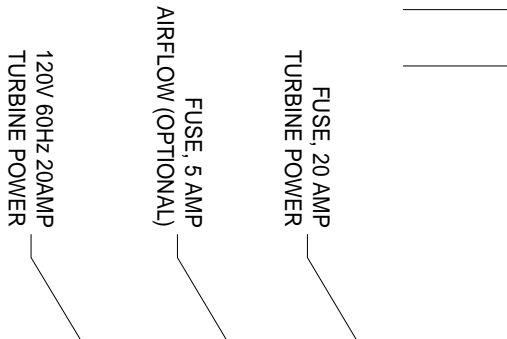
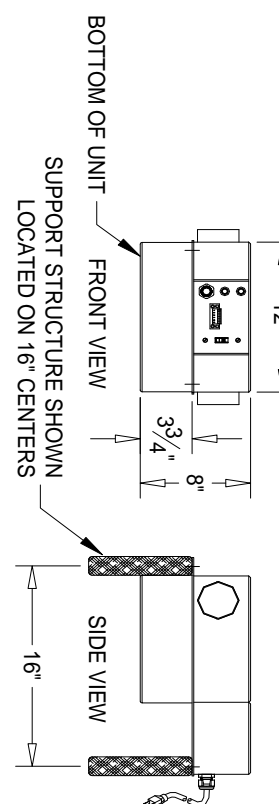
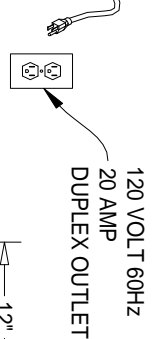
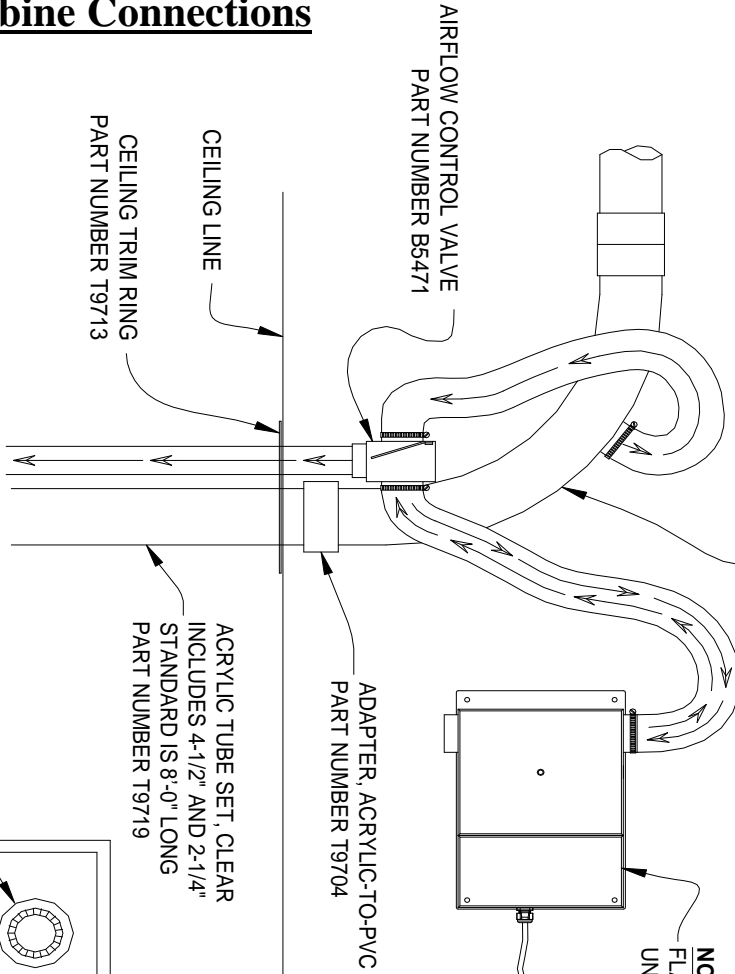

- 1 - VACUUM 24VAC
- 2 - PRESSURE 24VAC
- 3 - COMMON 24VAC
- 4 - AIRFLOW (OPTIONAL)
- 5 - AIRFLOW (OPTIONAL)
- 6 - NOT USED

TURBINE INTERCONNECT CABLE  
REQUIRES A MINIMUM  
OF 5 CONDUCTORS  
(STANDARD 7 CONDUCTOR  
CABLE IS SUPPLIED E0853)

# HA50 Remote Mounted Turbine Connections

**HAMILTON AIR**

MODEL HA-50  
TURBINE UNIT DETAILS  
TURBINE PART NUMBER B10004

Drawing Number : 99-954 Date : 4/3/09

# Customer Unit Connections

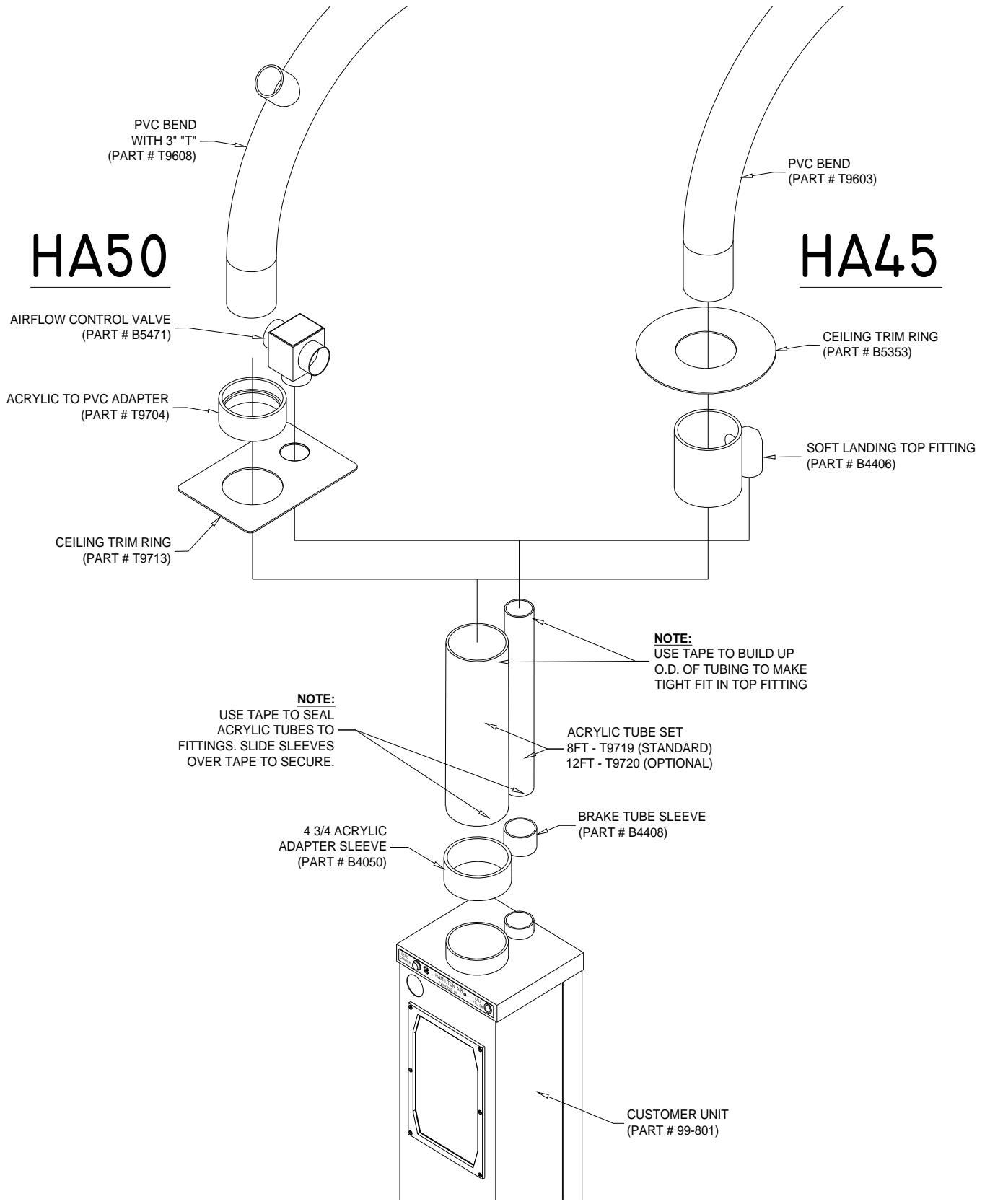

# HA45 Local Turbine

MICROPHONE

Rev - 1  
4/1/08 (ADDED NOTE FOR LSS)  
Rev - 2

- J7-1: Pressure Motor
- J7-2: Pressure Motor
- J7-3: Close Customer Door
- J7-4: Common for blower motors
- J7-5: Common for blower motors
- J7-6: Common for Door Motors
- J7-7: Vacuum Motor
- J7-8: Vacuum Motor
- J7-9: Open Customer Door

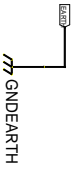
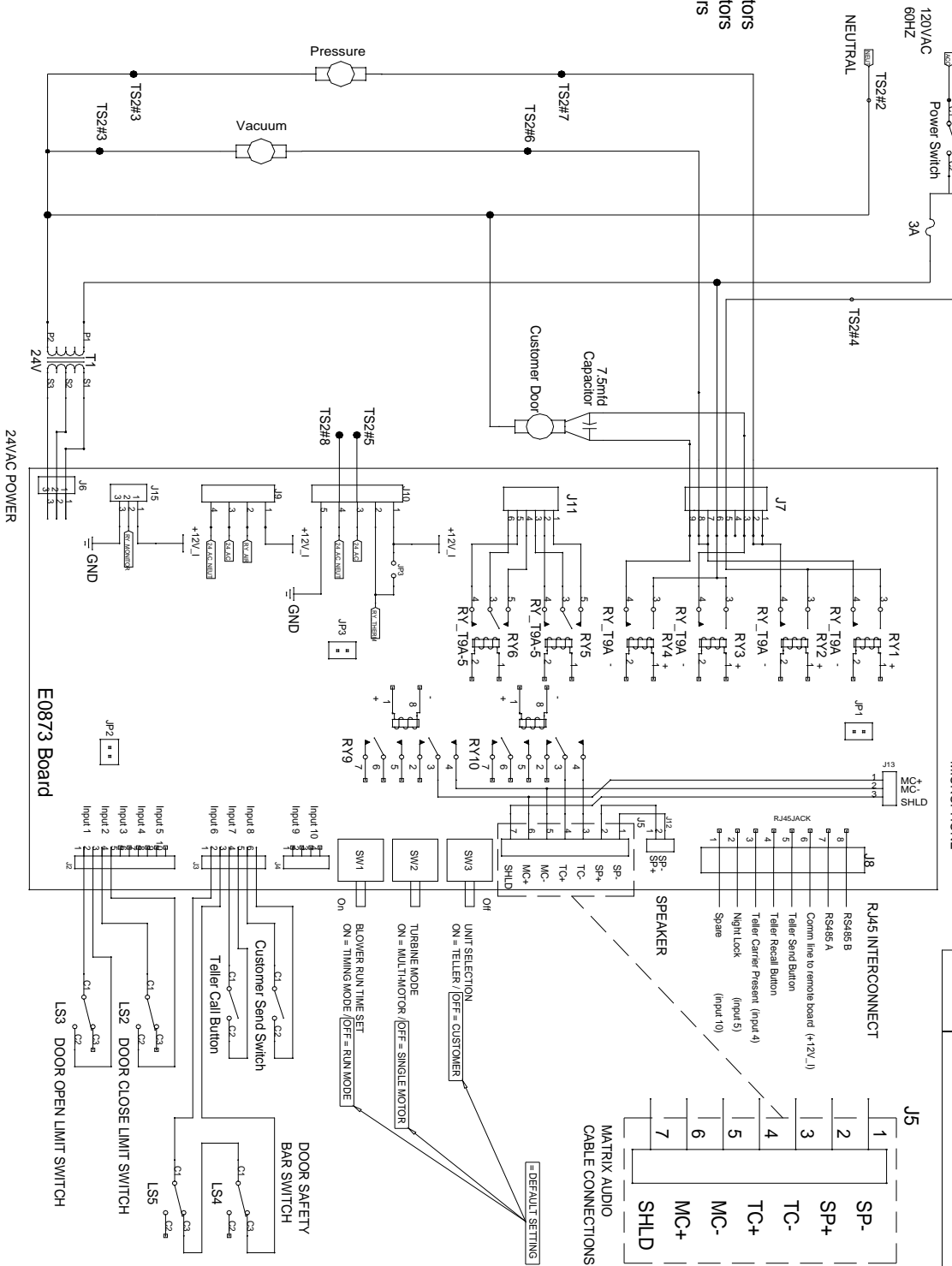

JP1 JUMPER 1: MULTIPLE BOARD JUMPER. JUMPER "ON" FOR NORMAL OPERATION WITH MANUAL TELLER UNIT. JUMPER "OFF" ONLY WHEN USED IN DUAL CONTROL BOARD SYSTEMS.

JP2 JUMPER 2: REMOTE INPUT JUMPER. JUMPER "ON" FOR NORMAL OPERATION WITH MANUAL TELLER UNIT. JUMPER "OFF" ONLY WHEN USED IN DUAL CONTROL BOARD SYSTEMS.

JP3 JUMPER 3: DOOR MOTOR AUXILIARY THERMAL PROTECTION JUMPER. JUMPER "ON" FOR NORMAL OPERATION IN ALL UNITS EXCEPT HA33. JUMPER "OFF" ONLY IF THE DOOR MOTOR HAS AUXILIARY CONNECTIONS FOR THERMAL PROTECTION (HA33 ONLY).

- Input 1: Door Open
- Input 2: Door Close
- Input 3: N/A
- Input 4: N/A
- Input 5: N/A
- Input 6: Door Safety
- Input 7: Call Button
- Input 8: Send Button
- Input 9: Optional auto door close
- Input 10: N/A

NOTE:  
HA45 SYSTEM DOES NOT HAVE LSS SAFETY SWITCH.

HAMILTON AIR

MODEL HA-45

ELECTRICAL DIAGRAM  
WITH I/O CONTROL E0873

Drawing Number: 99-1047 Date: 1/22/08



# Logic Wiring Detail with Remote Turbines

## HA45 Remote Turbine

- J7-1: Pressure Motor
- J7-2: Pressure Motor
- J7-3: Close Customer Door
- J7-4: Common for blower motors
- J7-5: Common for blower motors
- J7-6: Common for Door Motors
- J7-7: Vacuum Motor
- J7-8: Vacuum Motor
- J7-9: Open Customer Door

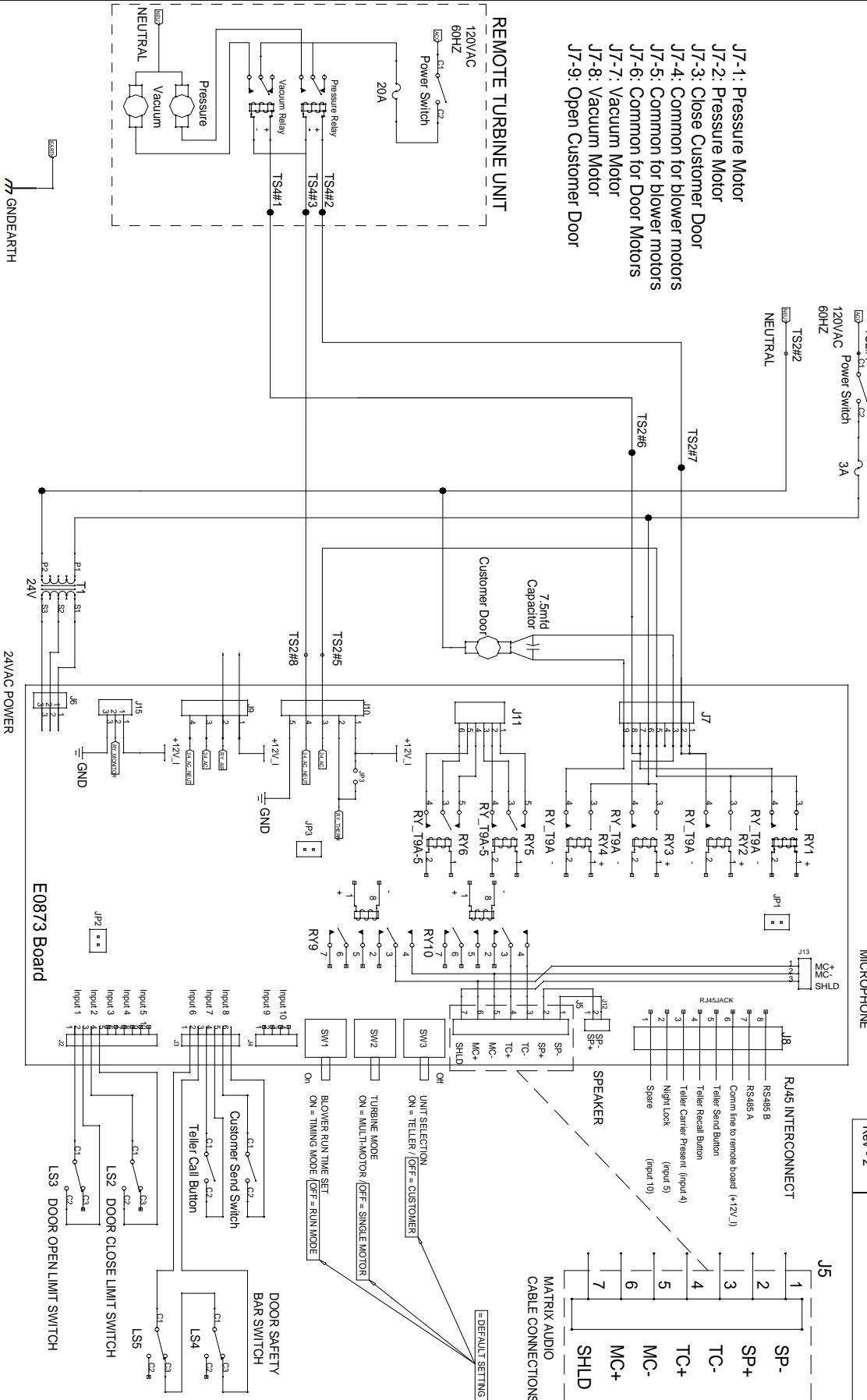

JP1 JUMPER 1: MULTIPLE BOARD JUMPER. JUMPER "ON" FOR NORMAL OPERATION WITH MANUAL TELLER UNIT. JUMPER "OFF" ONLY WHEN USED IN DUAL CONTROL BOARD SYSTEMS.

JP2 JUMPER 2: REMOTE INPUT JUMPER. JUMPER "ON" FOR NORMAL OPERATION WITH MANUAL TELLER UNIT. JUMPER "OFF" ONLY WHEN USED IN DUAL CONTROL BOARD SYSTEMS.

JP3 JUMPER 3: DOOR MOTOR AUXILIARY THERMAL PROTECTION JUMPER. JUMPER "ON" FOR NORMAL OPERATION IN ALL UNITS EXCEPT HA43. JUMPER "OFF" ONLY IF THE DOOR MOTOR HAS AUXILIARY CONNECTIONS FOR THERMAL PROTECTION (HA43 ONLY).

- Input 1: Door Open
- Input 2: Door Close
- Input 3: N/A
- Input 4: N/A
- Input 5: N/A
- Input 6: Door Safety
- Input 7: Call Button
- Input 8: Send Button
- Input 9: Optional auto door close
- Input 10: N/A

NOTE:  
HA45 SYSTEM DOES NOT HAVE LSS SAFETY SWITCH.

### HAMILTON AIR

MODEL HA-45 CUSTOMER UNIT  
ELECTRICAL DIAGRAM WITH REMOTE  
TURBINE PACK AND I/O CONTROL E0873

Drawing Number : 99-1048 Date : 10/15/09

Rev - 1	4/1/08 (ADDED NOTE FOR LSS)
Rev - 2	



## **Air Flow Kits:**

### **P/N B10020 for HA45 and B6530 for HA50**

#### **Airflow operation:**

The E0873 control board can be set-up to run an airflow kit for reducing condensation buildup in the tubes. Note: A separate airflow kit must be added to the tube system for this function to operate. The airflow function runs the pressure turbine motor on a larger 24VAC transformer. The airflow function is triggered three (3) minutes after the customer has sent the carrier inside or the teller has recalled the carrier. The airflow function is signaled by a LED light on the control board labeled "Airflow". When this LED is on, the airflow relay should be energized. When this relay is energized, the 120VAC power and neutral are disconnected from the pressure motor and the 24VAC power and neutral are connected. The airflow operation will be automatically interrupted if the tube system is activated.

The airflow function can be turned on or off depending on the weather and need.

- 1) Recall the carrier to the customer unit. (Make sure customer door is open)
- 2) Press and hold the carrier recall button (SW4) on the control board while pressing the customer send button on the customer unit.

The airflow LED indicator will flash to indicate if the airflow function is on or off.  
One flash = ON, Two flashes = OFF

Note: to toggle the function on and off, both SW4 and customer send must be released.

Model **HA-45** and **HA50** with I/O controls.  
Removable or remote turbine packs.  
Installation and Service Manual