

BUILDINGS ELECTRICAL SUPPLY

ONE DUPLEX OUTLET FOR EVERY TWO LANES 120 VOLT 20 AMP

TURBINE PACK INSIDE CUSTOMER UNIT

STANDARD DOWNSEND OPERATOR UNIT MODEL #99-349-I/O

CAT5 INTERCONNECT CONTINUES TO OPERATOR UNIT

4x4" J-BOX UNDER COUNTER IN OPERATOR KNEE SPACE AUDIO / VIDEO CABLES TO EXIT HERE

CONDUIT #2 FOR LOW VOLTAGE INTERCONNECT & AUDIO / VIDEO

CONDUIT #1 FOR POWER 120VOLT, 60HZ, 20 AMP DEDICATED BRANCH CIRCUIT REQUIRED FOR EACH CUSTOMER UNIT.

CLR30" TYP.

46 7/8" HEIGHT

15 13/16" DEPTH

6"

4"

10 3/16"

STUB UP CONDUIT 1" MAX ABOVE ISLAND SURFACE. ENTRY LIMITED TO 4" AREA AT CUSTOMER UNIT

10 3/16" CURB TO TUBE CENTER & UNDERGROUND CONDUIT ACCESS

4" CURB TO FRONT OF BASE

TRAFFIC FLOW

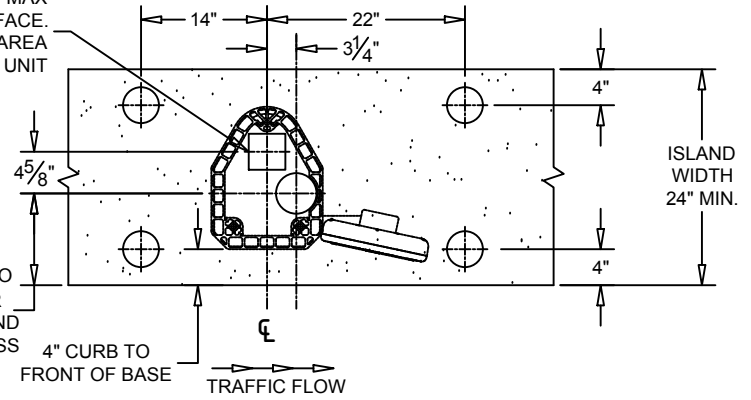
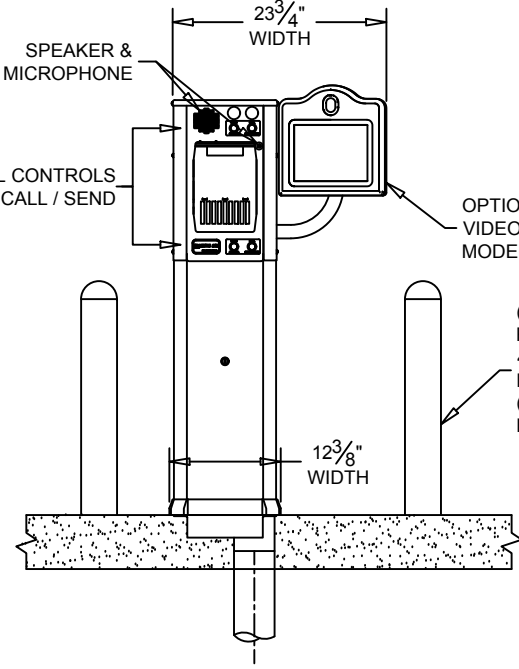

HAMILTON AIR.

PNEUMATIC TUBE SYSTEMS
MODEL HA1000-XLR DOWNSEND
CUSTOMER UNIT DETAILS

THESE DRAWINGS ARE THE PROPERTY OF HAMILTON SAFE CO. AND SHALL NOT BE REPRODUCED OR COPIED OR USED AS THE BASIS FOR MANUFACTURE OR SALE OF APPARATUS WITHOUT PERMISSION

DATE:	DRAWING NUMBER:	REVISION
1/13/2016	99-1160	--