

BUCKET CAPACITY = 4 1/4"H x 12 3/4"W x 7 5/8"D

THE EXTENSION OF THE BUCKET CAN BE ADJUSTED FROM 9" MINIMUM TO 17 1/2" MAXIMUM (COMES SET @ 17 1/2" FROM FACTORY)

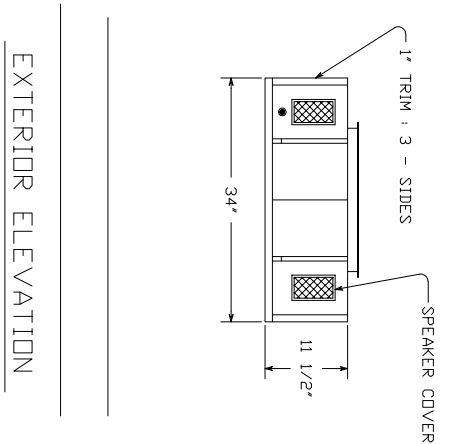

SECTION

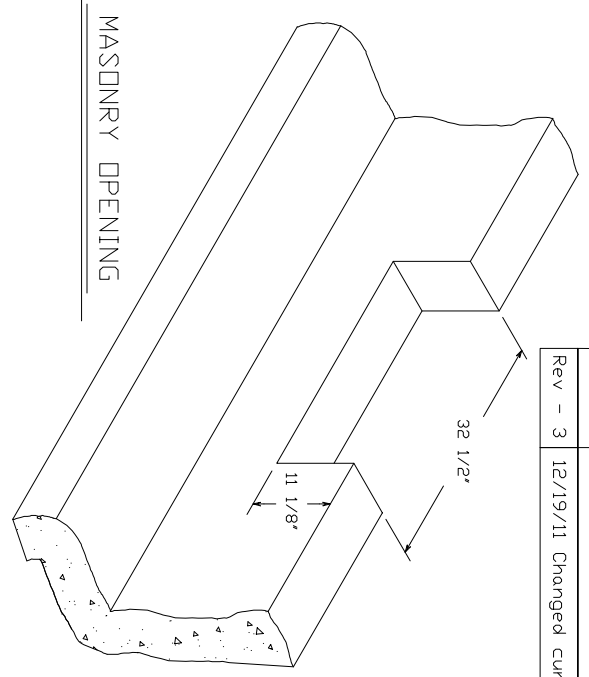
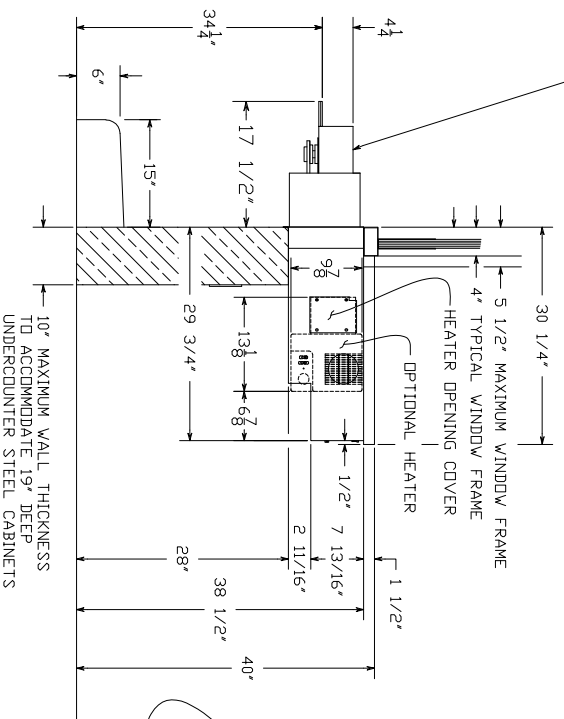

INTERIOR ELEVATION

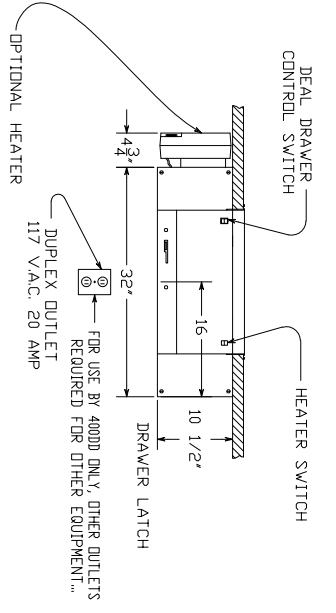

Rev - 1	2/19/01	ADDED OPT. HEATER
Rev - 2	7/13/04	CHANGE POWER REQUIREMENTS
Rev - 3	12/19/11	Changed curb dim.

* POWER REQUIREMENTS *

117 V.A.C. 60 HZ
125 AMP. WITH HEATER OPTION
2 AMP. WITHOUT HEATER OPTION.

<p>est. 1967</p> <p>HAMILTON</p> <p>CUSTOM MADE SECURITY</p>	<p>PROPRIETARY AND CONFIDENTIAL THESE DRAWINGS ARE THE PROPERTY OF HAMILTON SAFE CO. AND SHALL NOT BE REPRODUCED/COPY/USED AS THE BASIS FOR MANUFACTURE OR SALE OF APPARATUS WITHOUT PERMISSION</p>	<p>DESCRIPTION</p> <p>MODEL 400 DD - UL LISTED DEAL DRAWER UNIT</p>	<p>DRAWING/MODEL NUMBER</p> <p>95-136</p>	<p>DATE</p> <p>10/26/2021</p>
---	---	---	---	-------------------------------