

Basic installation instructions for the Hamilton Safe Hyde Park/Milford Vault Door

Document Number : 08-417

Installation Instructions

- **1.** Prepare opening: The outside face of the wall with the proper size block-out opening for the vault door of **50" Wide x 88" High**. The sides and top of the opening **MUST be plumb, level, and square**.
- **2.** Prepare the modular vault: Provide enough light inside of the modular vault and position at least one person inside the vault with the necessary tools.
- **3.** Staging vault door for lifting: Position the vault door flat on the floor, with the Top side of the door facing away from opening, so it can be raised to a vertical position at a right angle (90 degrees) to the opening. Then with appropriate help, raise the door to the vertical position.
- **Warning! Do not open the door in this position until after it is welded into the opening.**
- **4.** Moving the door into the opening: Using extreme caution and enough help move the door into the opening, walking one side at a time works best. When the frame is in opening and flat against the outside of the wall, check the vertical direction with a 4' level to make sure it is plumb in all directions.
- **5. Welding the door opening** with a minimum of (6) 1" welds along the outside of the door. Then unlock the combination locks and release the locking bolts by turning the handle. Carefully open the door
- **6.** Finish welding: Once door swing is acceptable the **door must be welded on inside of the vault to match outside**. Factory recommends at least 3" long welds top, bottom, and middle on both the inside and outside. (If necessary, use 12" angles provided to bridge the gap while welding the inside)

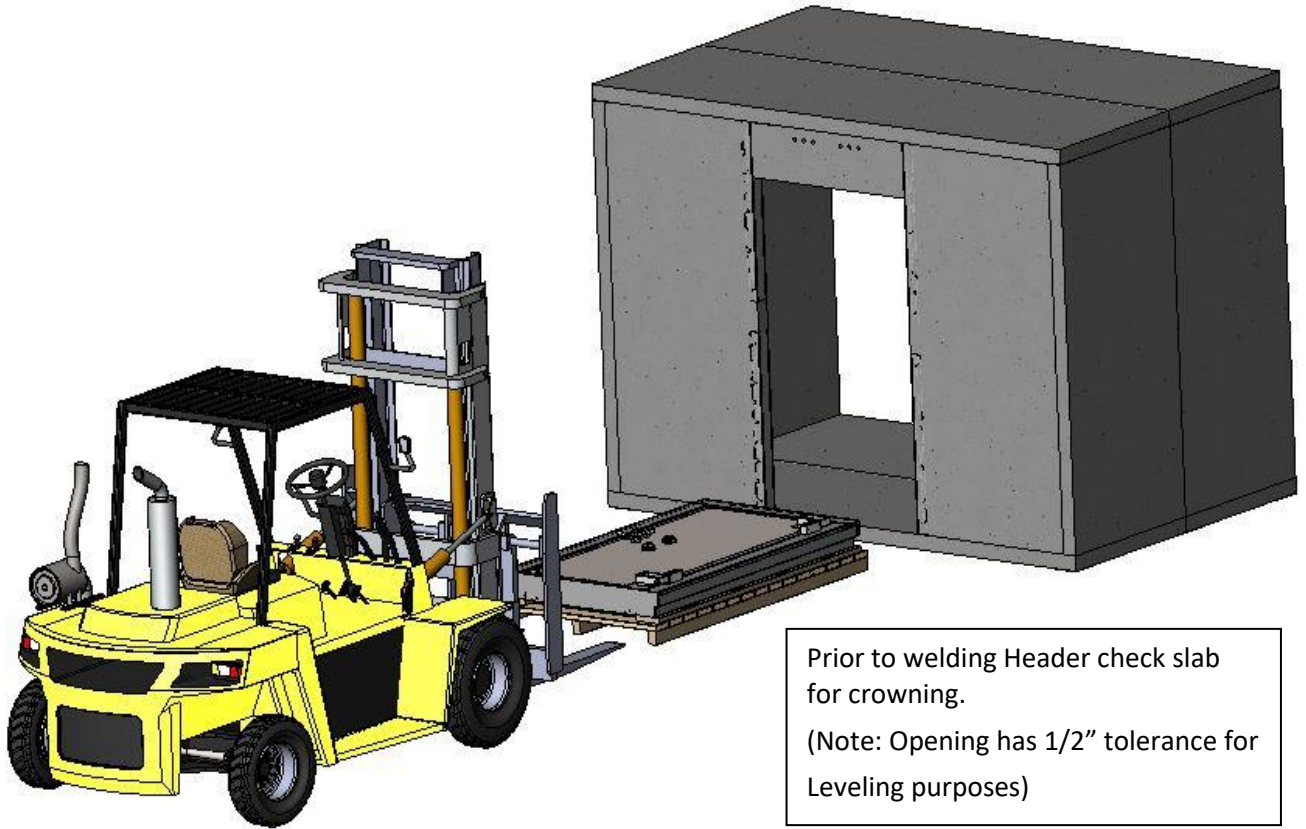

Prior to welding Header check slab
for crowning.
(Note: Opening has 1/2" tolerance for
Leveling purposes)

Hyde Park Vault door is shipped
Face up in the crate

Verify opening is plumb, level, and square (Jambs and Header should be coplanar). Verify opening is 50" x 88". (Note: Ceiling panels are to be installed flush the edge of the wall panels)

Stand Hyde Park vault door with top of the skid removed
The bottom shall remain on when standing up.

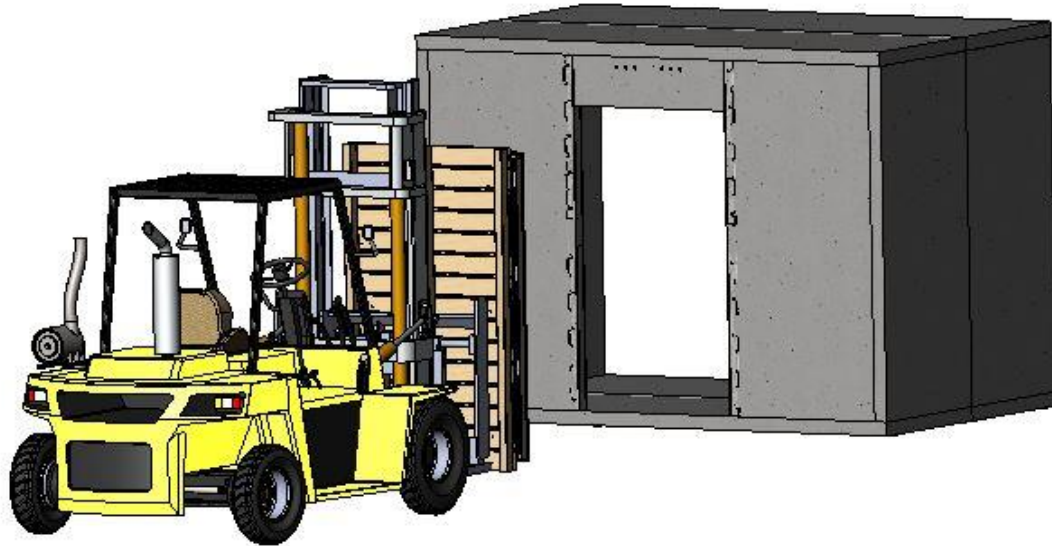

Note: You will have to remove the daygate and the back frame from the crate and set them aside.

Remove bottom skid and orient the door in the correct position.

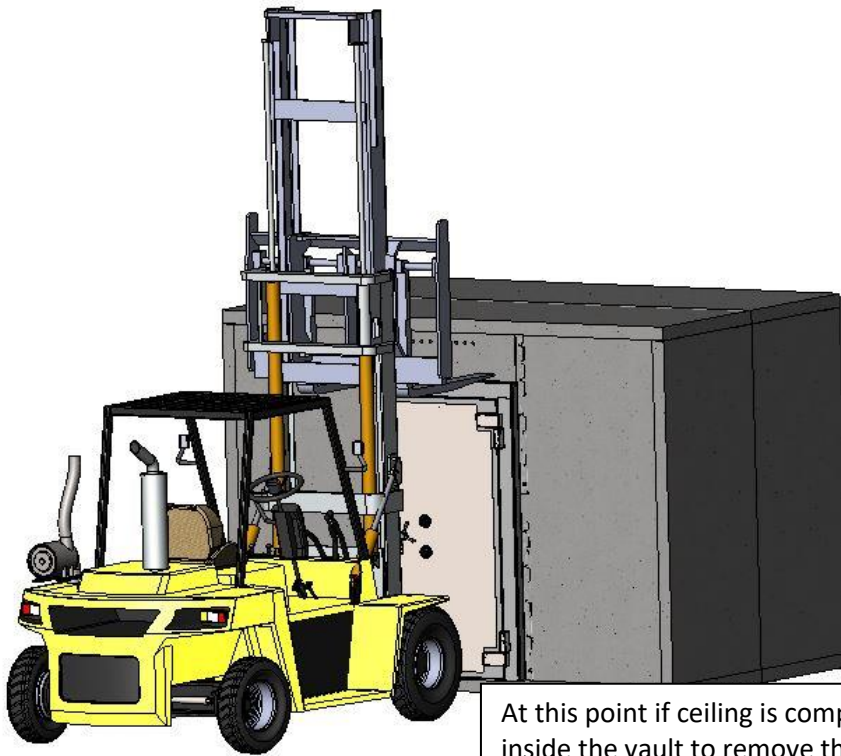
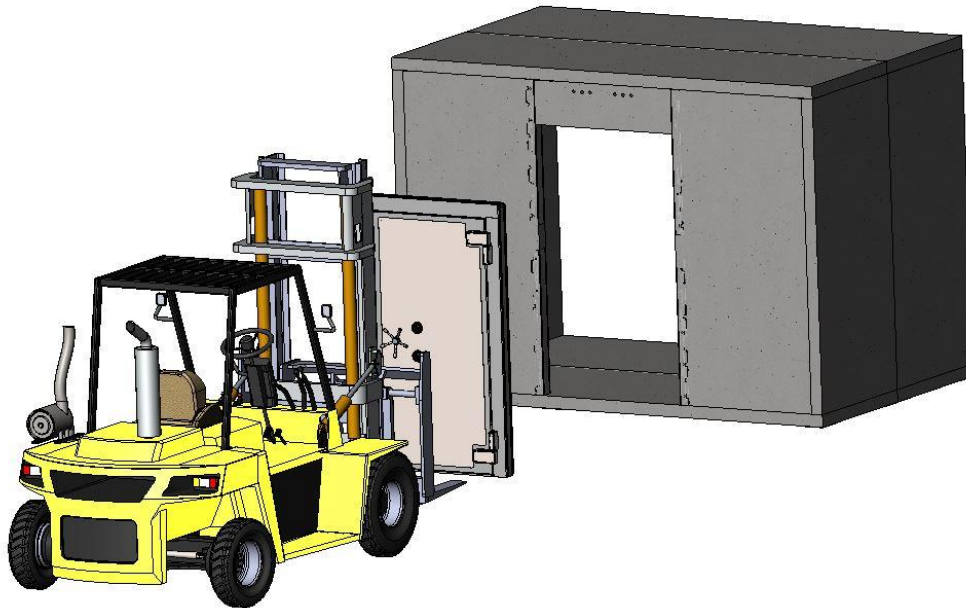

At this point if ceiling is complete, one installer must remain inside the vault to remove the bolts for the door retainer. (Note: If possible, leave one ceiling panel off to allow enough light in for final welding and allow you to pass tools back and forth.

Plumb in all directions using a 4'-0" level (6'-0" recommended). Take extra care to get perfect prior to welding door in place.

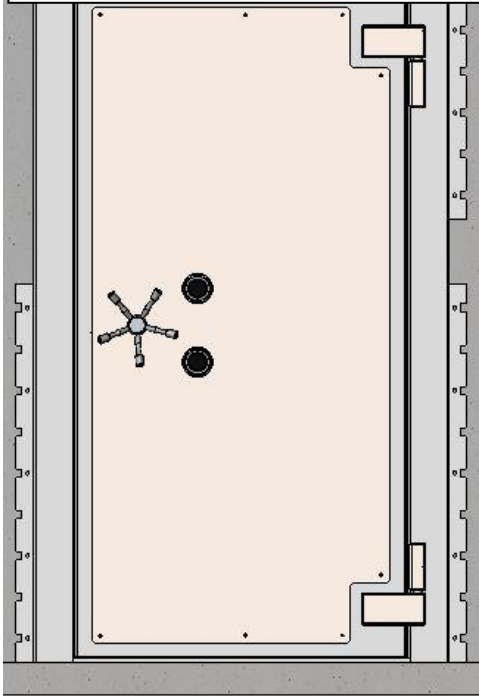

Once you have leveled and shimmed the door and all is acceptable, it is time to weld in place. Start by putting a 1" long weld in six places before opening the door.

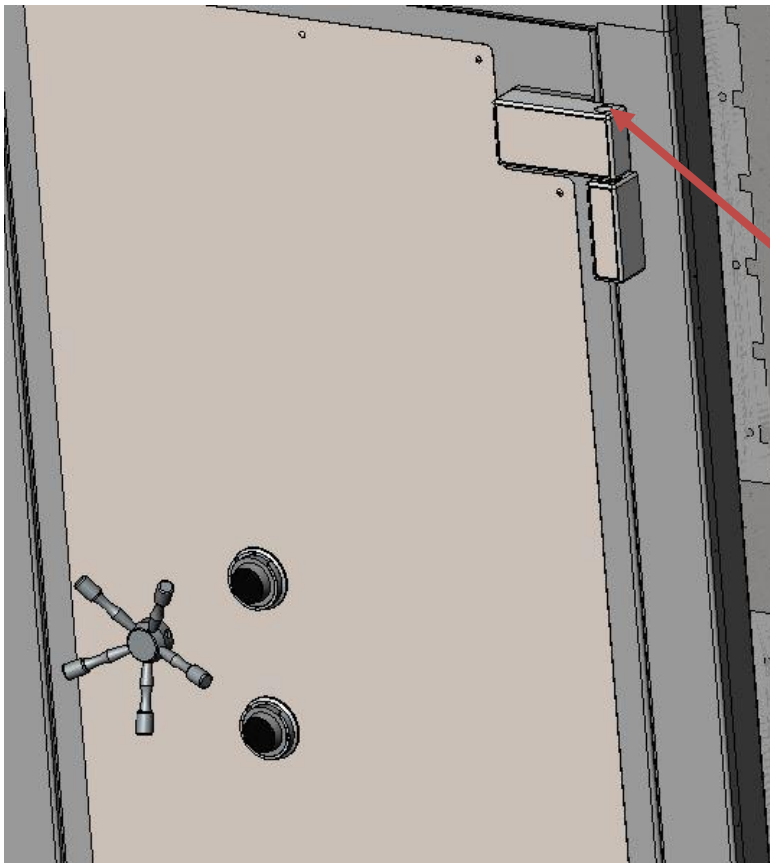
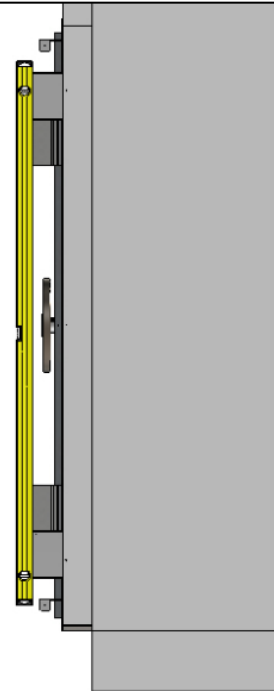

Raise the door up by adjusting the set screws on the top and bottom hinges. Get the door square before welding it in place.

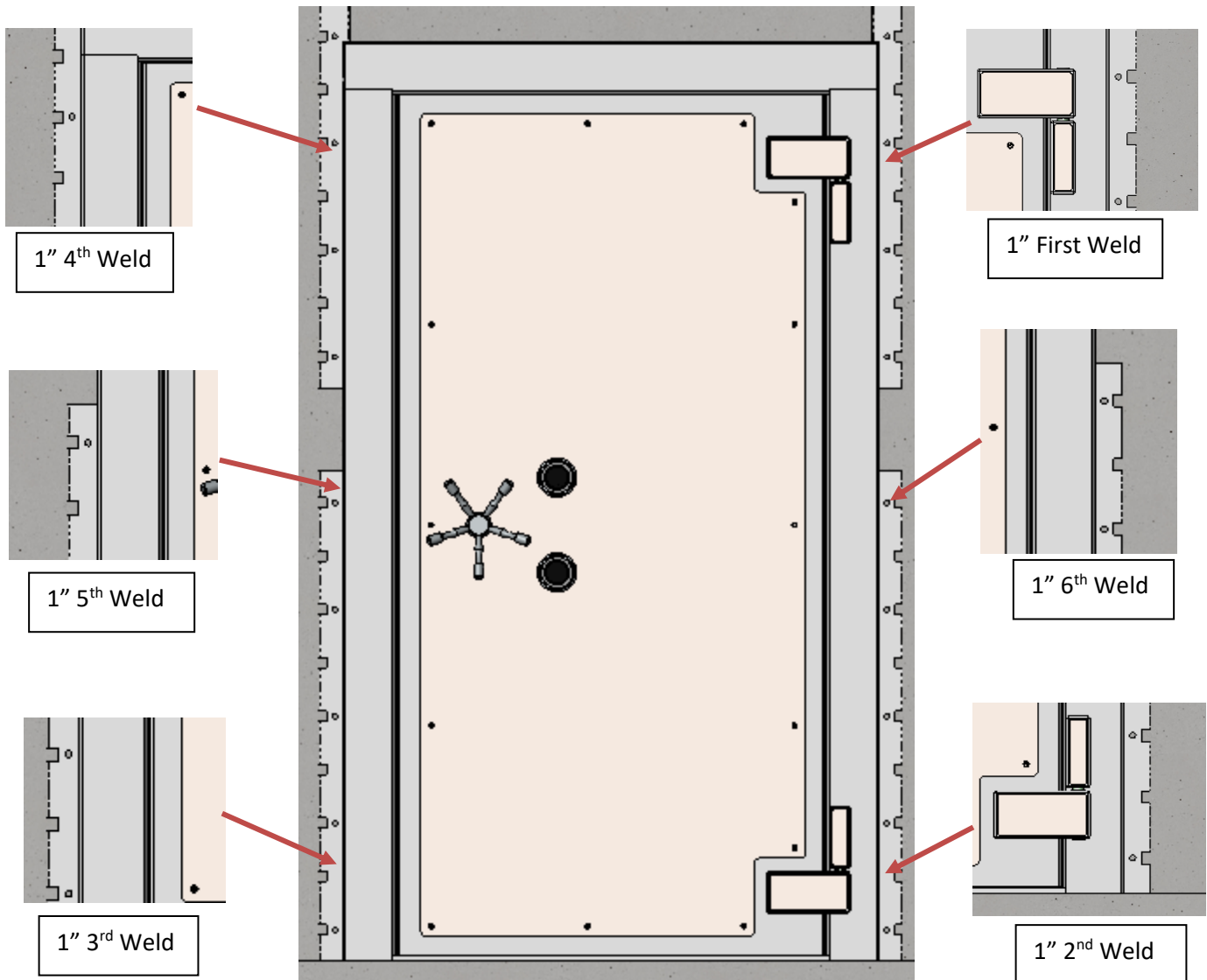

IMPORTANT!! A MINIMUM OF (6) 1" WELDS MUST BE COMPLETE BEFORE OPENING THE DOOR!!!

Approximate location shown above.

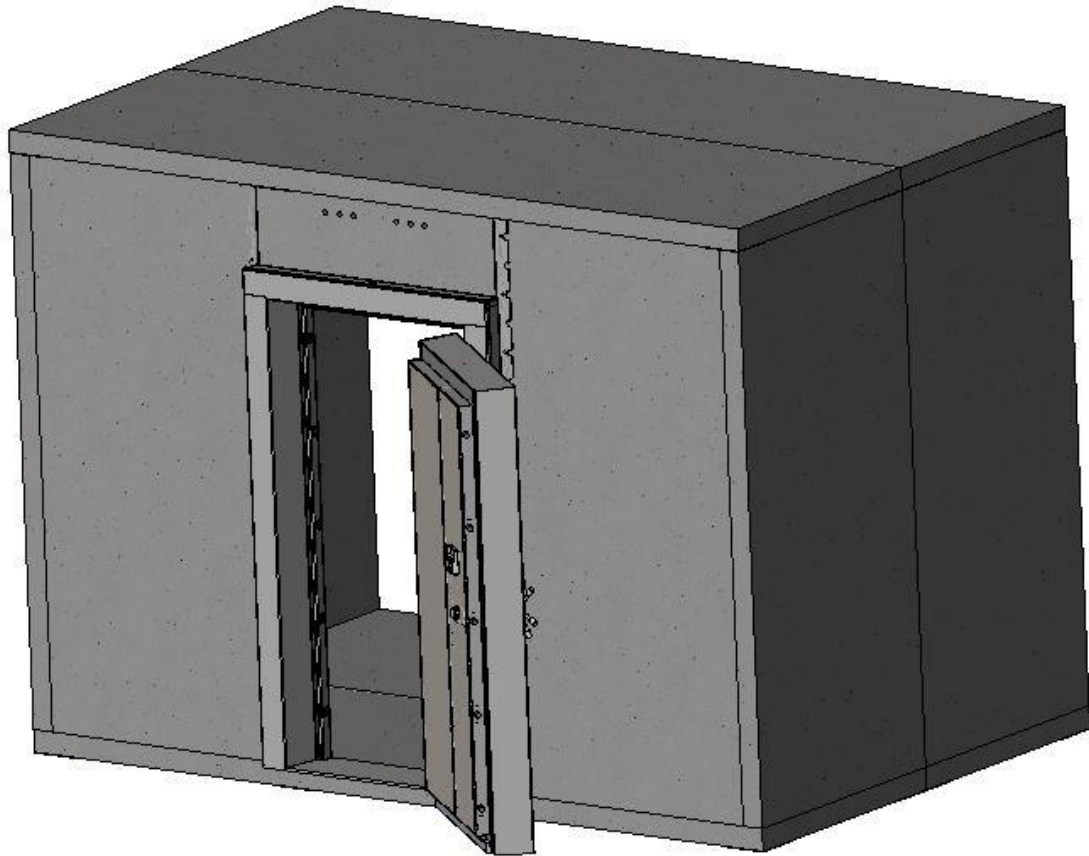

The door is now ready to open. If door swing is acceptable the door still **must be welded on inside of the vault** to match outside. Factory recommends **at least 3" long welds** top, bottom, and middle on the inside and outside. (If necessary, use provided 12" angles to bridge the gap while welding the inside)

Installing the Back Frame

Note: There is a hardware package for the back frame in the crate.

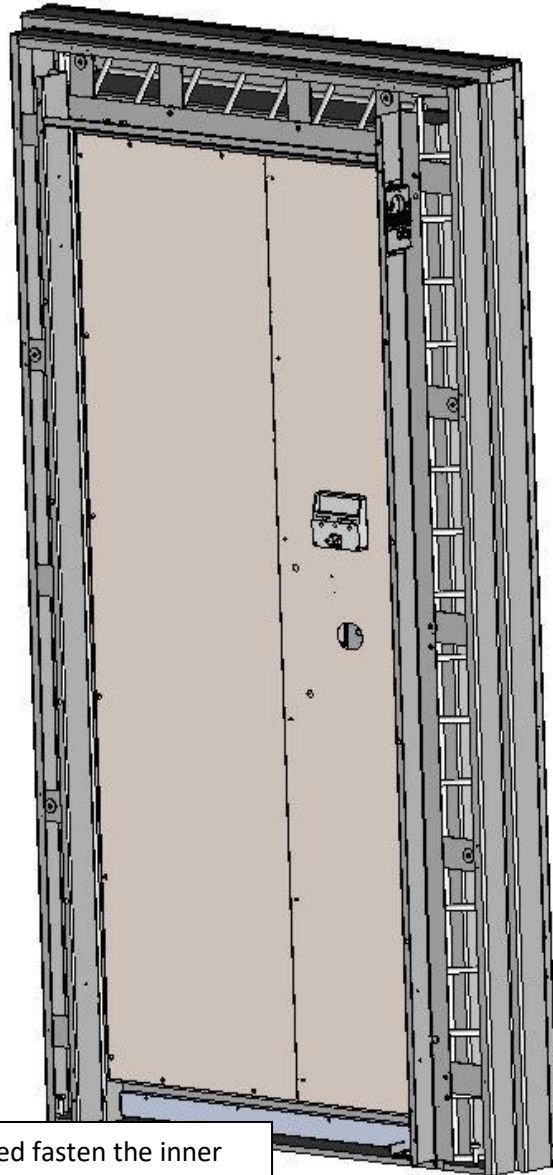

Note the position of the heat sensor. It should be installed on the strike side with the sensor lining up with the locking bolts. There is a circle knockout which will locate the heat sensor. It should be fastened with 2 8-32 screws and 2 KEPS nuts which are included in the hardware kit.

Using the 3/8 bolts provided fasten the inner left, the inner right, and the inner top.

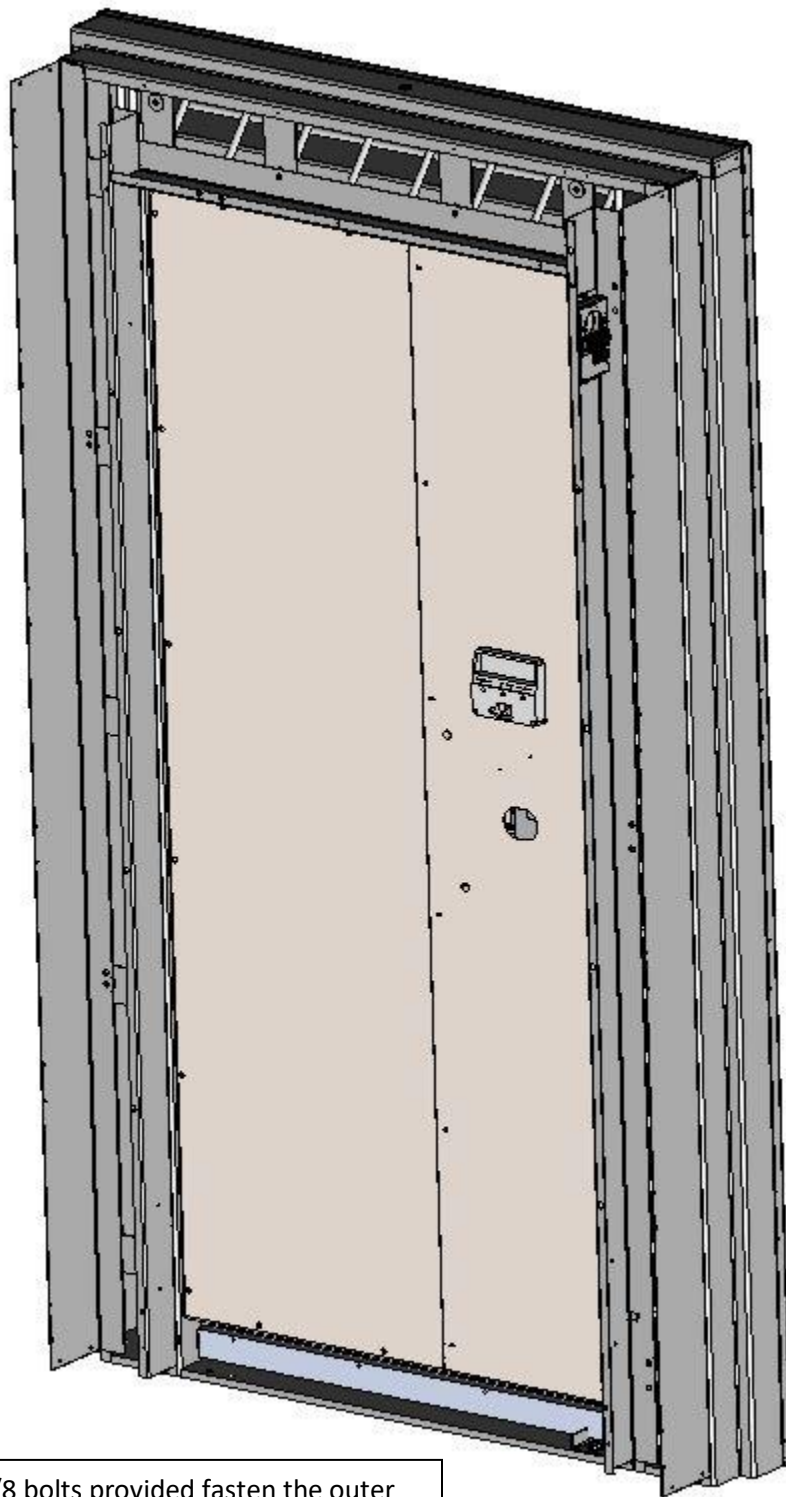

Using the 3/8 bolts provided fasten the outer left side and the outer right side

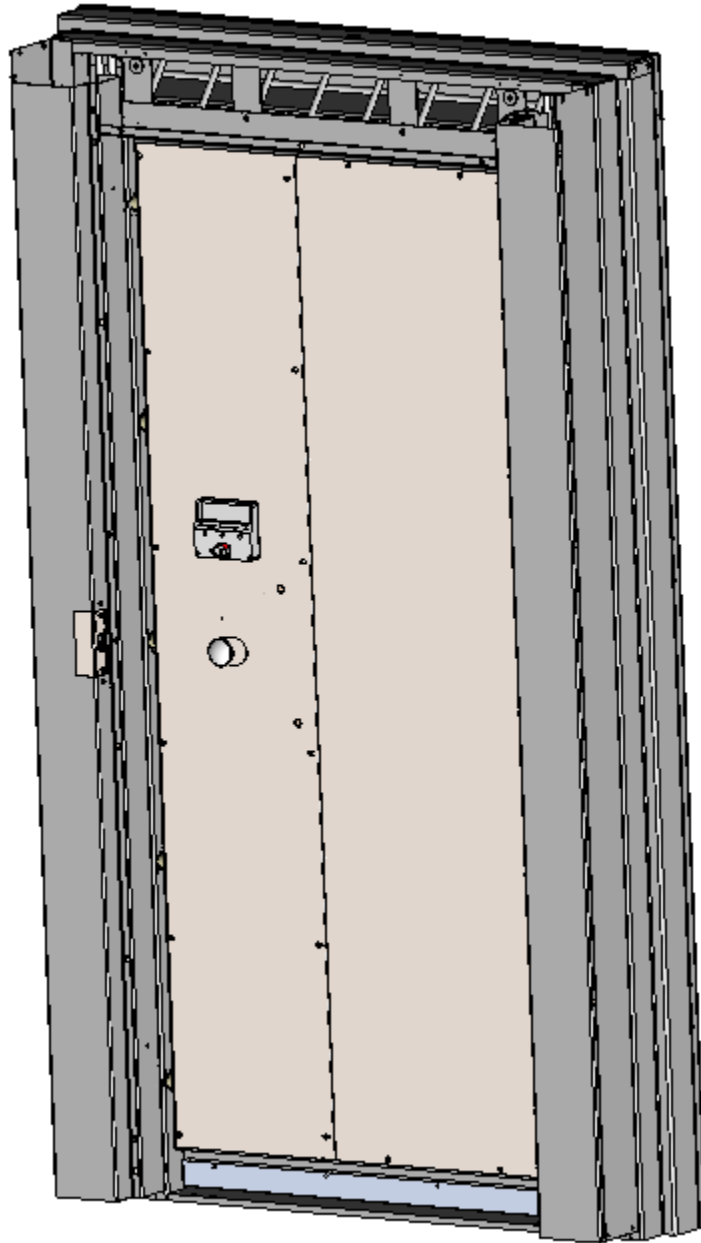

Using the 10-32 x 1/2 screws provided fasten the vertical rear strike extension and the vertical rear hinge extension. Both parts sit on the outside of the previously installed parts.

Note: It is easier to fasten the outside screws first.

Using the 10-32 x 1/2 screws provided fasten the outer top trim. The outer top trim sits on the outside of the previous installed parts.

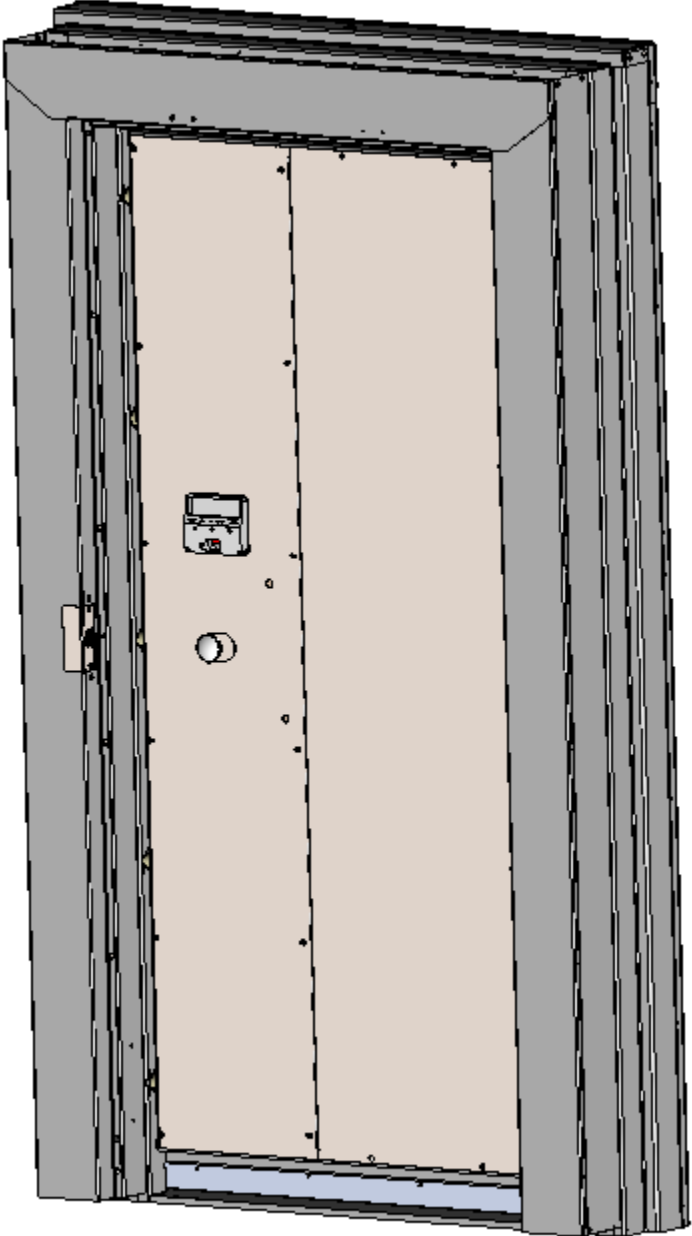

Note: The top of the door has been left open to run wires

Daygate Installation

- Note: Factory recommends installing the daygate after the modular vault has drywall and floor coverings installed
- Normally close to the opening date to avoid any damage.

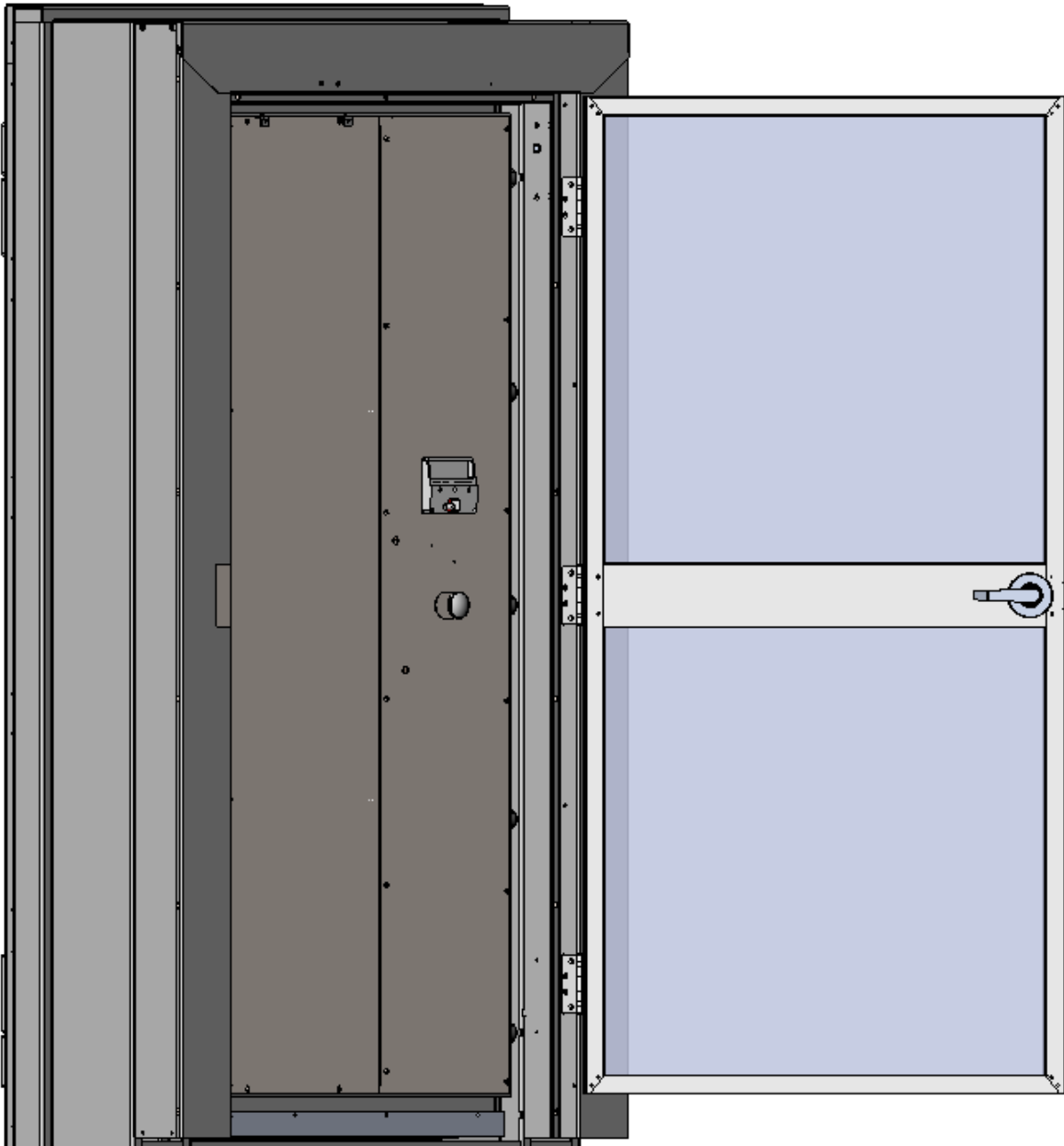

Use the provided flat head screws to fasten the hinges to the back frame.