



**5000 Series  
Audio Matrix**  
For Technical Support,  
call (513)-795-5332



**HAMILTON**  
BY **GUNNEBO**®

## Matrix Installation

Mount the audio (and video) matrix in an accessible but out of the way location near where the consoles will be located. The drawing below shows two mounting methods for all but the 5003 audio matrix which has a small plastic enclosure with mounting tabs.

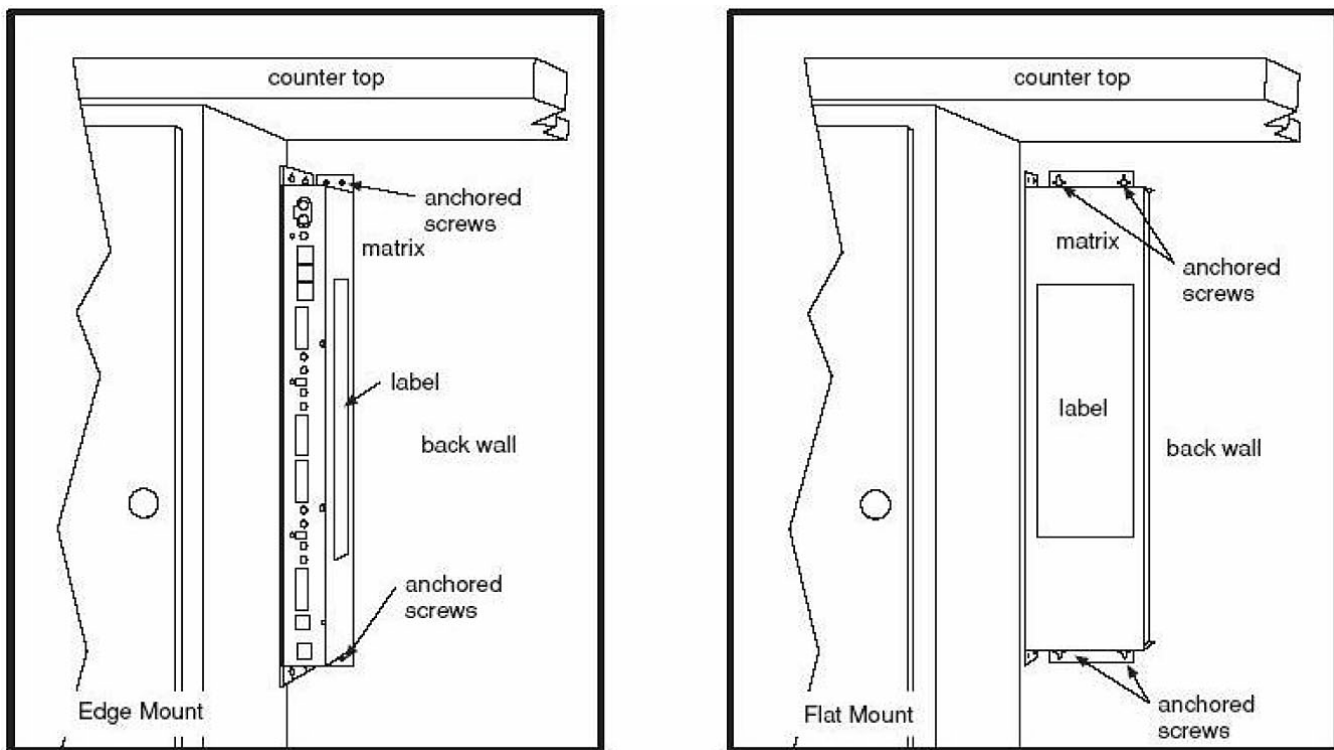

## Cable Considerations

Be sure to use the proper audio cable for connecting the matrix to the customer lanes. A special cable (part #E0680) is **highly recommended** for distances up to approximately 180 feet. This cable contains a 16AWG twisted pair for the speaker, a 20AWG twisted pair for the call button and a 20AWG twisted, shielded pair for the microphone. For distances over 180 feet it may be necessary to use a heavier gauge of wire for the speaker to prevent excessive loss due to the wire resistance.

It is **very important** that the microphone pair be shielded with its own drain wire. The drain wire should only be connected to terminal 7 of the matrix lane connector but cut off and taped at the remote end as shown on the drawing on the next page. Do not use cable with an overall shield or cable that has multiple shielded pairs that have a common drain wire. If the cable has multiple shielded pairs, with each pair having its own drain wire, only connect the drain wire from the microphone pair. Be sure to check the wiring and connections if audio equipment is being replaced but the old wiring is being used. Many older systems were wired with multiple shielded pairs and sometimes the drain wires were all connected together.

Another option for audio is to use Category 5 cable (5E & 6 are also acceptable) for distances up to 1000 feet. Using this type of cable requires the Cat 5 Lane Speaker Driver Kit (E0958-KIT). 110VAC must be available at the lane for this option. This kit can also be used to extend the length of standard E0680 audio cable to a maximum of 1000 feet.

## Power Supply Changes

4, 8 & 12 lane matrix boards have changed to utilize a barrel connector instead of the green phoenix connector for the power supply. Complete system orders will include the proper power supply. Matrixes ordered as replacement parts do not include a power supply (except 2-lane matrixes). Select the proper power supply from the following list or use the adapter as needed. 2-lane matrixes have a 1A power supply packaged with them.

E10171.....12VDC / 5.5A Power Supply w/Barrel Connector  
 E0736.....12VDC / 5.5A Power Supply w/Phoenix Connector  
 E10233.....12VDC / 3A Power Supply w/Barrel Connector  
 E10234.....12VDC / 3A Power Supply w/Phoenix Connector  
 E0946.....12VDC / 1A Power Supply w/Barrel Connector  
 E0947.....12VDC / 1A Power Supply w/Phoenix Connector  
 E10159.....Power Adapter, Phoenix to Barrel Connector

## Matrix Wiring Diagram

Refer to the drawing below for standard wiring connections. The drawing shows a 4-lane matrix but the same wiring applies to all versions. Observe the following guidelines.

- The ground wire connection shown for the audio matrix is not required for the 5003 matrix.
- For audio-only systems the audio console(s) may be plugged into any of the console ports of the audio matrix. When video is used the console port numbers must match on the audio and video matrixes for a particular teller position.
- The interconnect wiring shown in the drawing below refers to the recommended audio cable (part number E0680). See the section “Cable Considerations” on the previous page if using other cable.

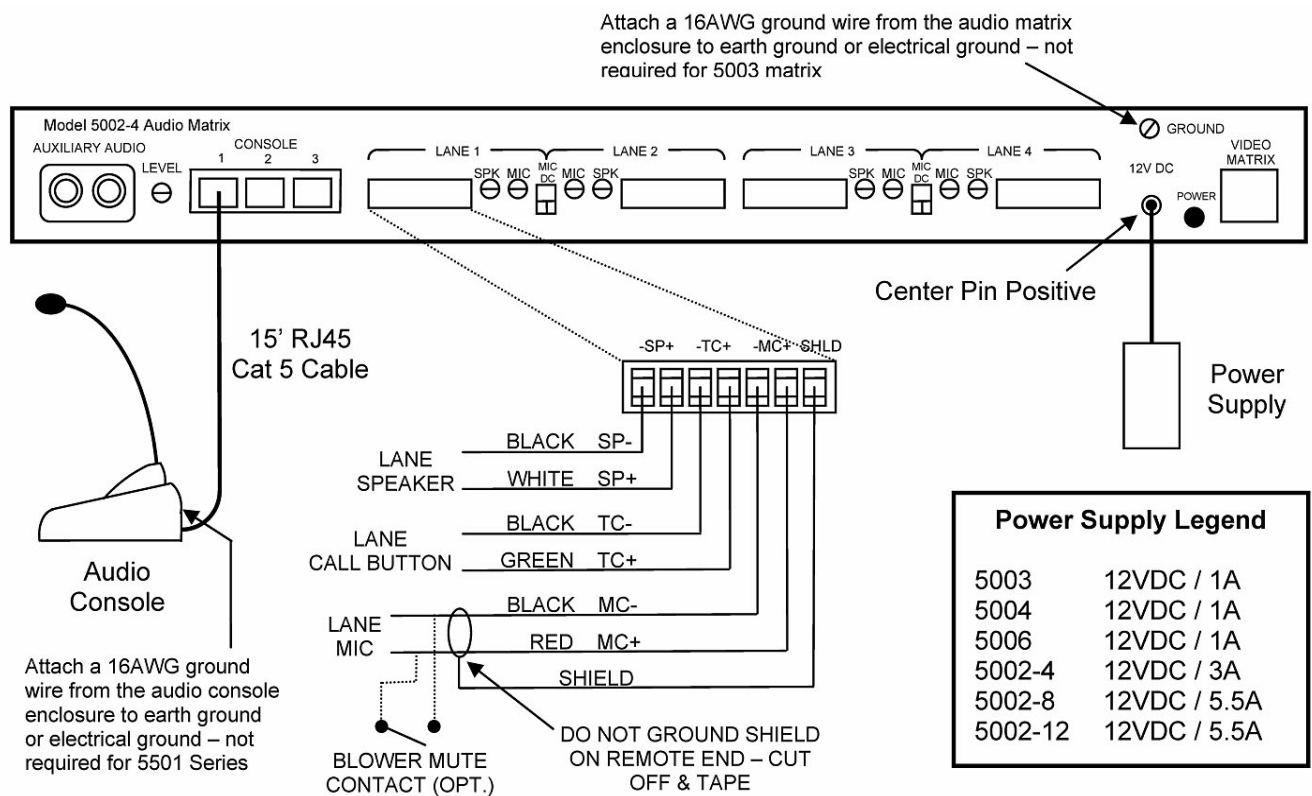

**See the section “Cable Considerations” if not using E0680 audio cable.**

## Audio Matrix Switch Settings

Refer to the chart below for the dip switch pack located on the end of the audio matrix. Factory settings are shown in bold. *Cycle power to the matrix after making any changes to these switches.*

Feature	Switch #	Up (Off)	Down (On)
Lane Order <sup>1</sup>	1	<b>Normal</b>	Reverse
Console Limit <sup>2</sup>	2	<b>2 Per Lane</b>	1 Per Lane
Delayed Unmute <sup>3</sup>	3	No Delay	<b>1 Second</b>
Delayed Unmute <sup>3</sup>	4	<b>No Delay</b>	2 Seconds
Aux. Audio Mode <sup>4</sup>	5	<b>Normal</b>	Noise Abate
Call Tone Default <sup>5</sup>	6	<b>Normal</b>	Erase
Echo Canceller <sup>6</sup>	7	<b>Dynamic Learning</b>	Fixed Learning
Background Noise Cancellation <sup>6</sup>	8	Off at Startup <sup>7</sup>	<b>On at Startup</b>

- <sup>1</sup> Determines whether the console lane buttons work from left to right (normal) or right to left (reverse). This switch must be UP for 5501 Series consoles.
- <sup>2</sup> Determines if more than one console can select the same lane at the same time. Volume levels will be reduced when multiple consoles select the same lane. This switch has no effect with a 5003 matrix since it can only have one console.
- <sup>3</sup> The mute circuit is wired so the closure of an auxiliary contact of the blower relay shorts across the lane microphone to mute the incoming audio while the blower is running. These switches determine the length of delay after the microphone short is removed until the incoming audio comes back on to allow for motor wind down time. The switches can be combined to give a 3 second delay.
- <sup>4</sup> Noise Abate mutes the auxiliary audio (if used) until the call button is pressed or the lane is put on hold. This feature is generally used if the facility is near a housing development to prevent complaints from the residents. This switch has no effect with a 5003 matrix.
- <sup>5</sup> This determines whether the call tone programming goes back to factory default (erase) when the system goes through a reset or whether the programming is saved (normal) and only applies to older matrixes. The programming is always saved with a 5000 Series matrix regardless of the position of this switch.
- <sup>6</sup> These switches as listed are for features in all 5501 Series consoles and 5001 Series consoles that are revision 3.1 or higher. See a full explanation of these features in the section “Echo Canceller & Background Noise Cancellation” of the “5000 Series Audio/Video System Installation & Service Manual” document.
- <sup>7</sup> 5501 Series consoles with revision 2.4 or higher firmware do not allow background noise cancellation to be turned completely off. The “off” position with these consoles is actually “on partial”.

**MIC DC Switches:** These switches only exist on older 5000 Series audio matrixes and are used to determine if the lane microphone is a Dynamic (UP) or Electret Condenser (DOWN) type. Since the electret type is standard (and recommended) this switch must be down or the mic will not work. All newer matrixes are hard-wired to this position and do not include the switches to avoid service issues.

## Adjusting the Audio System

The speaker (SPK) and microphone (MIC) pots on the audio matrix (see page 3) provide the main volume adjustment for the system. There are a set of pots for each customer lane. The speaker pot adjusts the outgoing volume to the customer lane while the microphone pot adjusts the incoming volume to the teller. The best adjustments are made with one person at the audio console and another person in a vehicle at the customer lane.

- Adjust the SPK and MIC pots based on the orientation of a clock. When a pot is turned all the way down (counter-clockwise), the left side of the screwdriver slot will be pointing to approximately 7:00. When a pot is turned all the way up (clockwise), that same side of the screwdriver slot will now be pointing to approximately 5:00. Mid range of the pot is 12:00. Audio matrixes leave the factory with these pots set at approximately 10:00.
  - If wireless headsets will be used, make all matrix adjustments while in Console Mode using the console speaker and microphone, not the headset. After the matrix is adjusted satisfactorily then switch to Headset Mode and adjust the headset itself to balance the volume levels obtained with the console. Refer to the headset documentation for more information.
  - When using 5012 or 5512 Remote Handsets, make all matrix adjustments while using the remote speaker and microphone at the lane, not the handset. Then lift the handset off the cradle and use the pots on the handset board to balance the volume levels. See the handset documentation for more information.
  - When using standard audio cable: Select a lane from an audio console and speak directly into the console microphone at the recommended distance \*. Adjust the speaker pot for adequate but not excessive volume at the lane. The default setting is ideal for many installations and can be reduced on some. Getting too close to the mic or setting the pot too high can have a negative affect and add static sounding artifacts to the audio.
  - When using Cat 5 cable or standard audio cable with the E0958-KIT: Leave pot R1 on the E0958 lane module set to it's maximum setting (fully counter-clockwise). Set the speaker pot on the matrix to 8:30. Select a lane from an audio console and speak directly into the console microphone at the recommended distance \*. There should be adequate volume at the lane at this setting since the amplification takes place at the lane module. Only increase the speaker gain at the matrix if necessary and then in small 30 minute increments and retest.
  - With the lane still selected adjust the mic pot for adequate but not excessive incoming volume while the person at the customer lane speaks toward the microphone. Make small adjustments at a time – approximately 30 minutes. Do not set the mic pot higher than necessary. Do not adjust the volume using the console volume arrows at this time. The console volume can later be adjusted by each teller for their individual preference. Note that any changes made using the console volume arrows will revert back to a default level whenever the system is reset.
  - Do not automatically assume that all lanes should be adjusted to the same settings. Acoustics and other factors can vary from lane to lane, especially with deal drawers.
  - All modern consoles operate in full duplex mode, meaning audio is active both directions at the same time. However, to give the teller priority in the conversation, the incoming volume will be reduced while the teller speaks into the microphone.
- \* The recommended distance for speaking into the console microphone is 1” to 2” on all consoles except for 5501 consoles that have revision 1.1 or 2.2 firmware. For those consoles the recommended distance is 3” to 6”.

## Changing the Call Tone Type & Volume

The call tone type and volume are system wide parameters which are stored in the audio matrix. Any audio console in the system can be used to change these parameters as follows.

- Press the LANE 1 key and the HOLD key at the same time – lane 1 & 2 indicators light orange.
- Press the LANE 2 key to rotate through the call tone types until the desired tone is heard.
- Press the LANE 1 key to rotate through the volume levels until the desired level is heard.
- Press the Volume ▼ key to select a single call tone (1 beep) or repeating tones (2 beeps). Repeating call tones will sound every few seconds until a teller selects the lane.
- Press the HOLD key to exit programming mode.

## Troubleshooting Tips

- **System won't initialize (console lights continue to blink red or stay lit)** – The audio consoles, audio matrix and video matrix all communicate by RS-485 through the Cat 5 cables. A problem with any of these devices can cause a system wide problem like this. Power down and disconnect all but one audio console – also disconnect the video matrix if present. Power up and see if the system will initialize with a single console. If it does, start adding devices back one at a time until it fails again to determine the cause. If the first console failed to initialize, try a different one. Don't rule out the possibility that a storm or power surge could have damaged multiple devices. Also be aware that some matrix failures are only related to a particular console port.
- **Power supply issues** – 1A “wall wart” power supplies have an internal fuse. If the output gets shorted the power supply will be destroyed. The 5.5A power supplies are regulated and protected from short circuits. Old Samlex power supplies (large, heavy enclosure) should be watched closely and replaced if possible. As they begin to break down with age their output will not have clean DC current and the voltage will slowly rise, sometimes to levels than can damage equipment. When using old 4101 audio/video consoles it may be necessary to use a power supply larger than the recommendation shown on page 2 since the LCD is also drawing power from the same source. In most cases a 5.5A power supply will work. Contact tech support at 877-236-0245 if you are unsure about the power supply requirements for a particular system.
- **Audio issues** – Isolate audio problems by determining if the problem exists only when using a particular audio console or when communicating with a particular lane. Before deciding that a particular console is bad, try plugging it into a different port of the matrix. Lane connectors can also be swapped at the matrix to see if a problem follows the actual lane or stays with the same lane number. This will help determine if the problem is in the matrix or has to do with the lane cable or lane device. Also while troubleshooting be aware that the main amplification for outgoing audio is in the matrix but the main amplification for incoming audio is in the console. If a particular system is hard to keep adjusted be sure to verify proper wire type and connections. See the sections “Cable Considerations” and “Matrix Wiring Diagram”.