

# Hamilton Security Solutions for the Cannabis Industry

Maximum security for retailers,  
growers and distributors



est. 1967

# HAMILTON

BY **GUNNEBO**<sup>®</sup>

CUSTOMER SECURITY

www.hamiltonsecurity.com

# Safeguard Your Assets, Staff & Customers

Choose any combination of vaults, safes, drive-up and walk-up systems, and electronic security equipment

In the state-regulated cannabis industry, growers, distributors and retailers looking to run a successful business within the rules and a very cash-intensive market face a multitude of security challenges.

While the rules and regulations vary by state, most compliance standards require security equipment and systems that ensure cannabis access is regulated, product is secure, and inventory is tracked, monitored and reported in the event of a security incident.

Highly secure physical equipment and video surveillance are crucial for cannabis owners to not only comply, but to protect their business from threats such as internal theft, fire and break-ins. Working together, they provide multiple layers of security across your entire cannabis operations.

## HAMILTON SECURITY SOLUTIONS TO PROTECT YOUR CANNABIS FACILITY

Hamilton Security provides a full line of vaults, vault doors, safes and locks, drive-up and walk-up systems, depositories and electronic security systems that meet and often exceed the security industry's highest anti-burglary and fire protection standards.

Hamilton's custom and standard security equipment, built with rugged stainless steel and the highest UL-certified ratings, assures your cannabis business maximum security and protection from fire, flood, burglary, theft and natural disasters.

These security systems, combined with electronic security solutions, provide the depth of defense you need to safeguard your assets, employees and customers, while meeting cannabis compliance standards.

## VAULTS & VAULT DOORS



These UL rated vault and vault doors provide maximum security for interior storage of inventory and cash. Easily control who has access to the vault with three-movement time locks or biometric fingerprint entry locks.

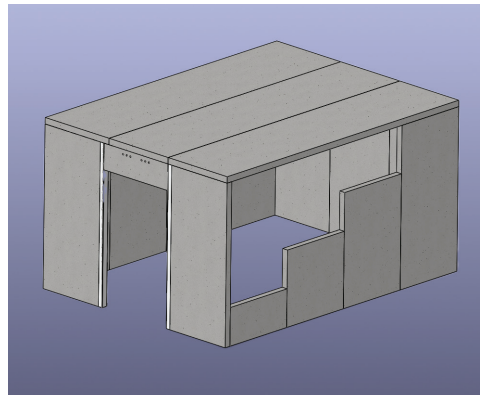

- UL RATED VAULT PANELS CLASS 1,2,3
- UL RATED VAULT DOORS CLASS M, 1, 2, 3
- UL LISTED THREE-MOVEMENT TIME LOCK - 144 HOUR RESETTABLE
- EXTRA LAYER OF SECURITY WITH BUILT-IN HEAT DISSIPATING LOCKING BAR
- MAINTENANCE FREE STAINLESS STEEL BALANCE PAINTED
- STANDARD SIZE 36" X 80" CLEAR OPENING; CUSTOM SIZES AVAILABLE



# TL-15, TL-30 & TRTL-30X6 SAFES



TL15



TL30



TRTL30



## SECURITY RATINGS:

- TL-15, TL-30, TL-30X6, TRTL-30X6
- 2-HOUR FIRE RATING

## BODY:

- 2" COMPOSITE FOR TL-15 AND TL-30
- 4" COMPOSITE FOR TL-30X6 AND TRTL-30X6

## DOOR:

- TL-15 = 2", TL-30 = 4"
- TRTL-30X6: UL LISTED 30 MINUTE TORCH AND TOOL ATTACK ON ALL 6 SIDES

## BOLTWORK:

- SOLID STEEL BOLTS
- 4-WAY BOLTWORK FOR TRTL-30X6
- MECHANICAL RELOCKER INCLUDED TO PROVIDE A SECONDARY DEFENSE

## SIZES:

- STANDARD AND CUSTOM SIZES AVAILABLE

# DRIVE-UP, WALK-UP & DEPOSITORIES



HA 1000-XLR  
downsend



HA 1000-XLR  
upsend with  
optional  
customer video



Hamilton's family of pneumatic tube systems, transaction drawers, bullet-resistant windows and depositories provide safe, secure transfer of inventory and cash between employees and customers.



## HA 1000-XLR

- EASY TO OPERATE WITH SETS OF CALL/SEND BUTTONS ABOVE AND BELOW CARRIER

## 400 DD TRANSACTION DRAWER:

- UL LEVEL 3 RATING, .44 MAGNUM BALLISTIC PROTECTION FROM ATTACKS

- INCLUDES HAMILTON'S 5502 SERIES AUDIO

## BULLET RESISTANT WINDOWS:

- UL LEVELS 1, 2 AND 3; HURRICANE RATED

## DEPOSITORIES:

- UL LEVELS 1, 2 AND 3; HURRICANE RATED
- HIGH SECURITY ANTI-PHISH FEATURES

## SIZES:

- STANDARD AND CUSTOM SIZES AVAILABLE FOR ALL UNITS AND WINDOWS

# ELECTRONIC SECURITY SYSTEMS



High-security cameras and access control systems prevent risks of intrusion and theft. Video surveillance detects instances of potential theft and reduces investigation time.



## CAMERAS:

- EVERY SQUARE INCH OF SPACE IN CANNABIS FACILITIES COVERED BY VIDEO SURVEILLANCE 24/7

- MINIMUM OF 720 P RESOLUTION, 90 DAYS OF VIDEO STORAGE TO MEET REGULATORY REQUIREMENTS

- INTELLIGENT IP VIDEO TO FIND SUSPECT ACTIVITY QUICKLY

## ALARMED ACCESS CONTROL SYSTEMS:

- ACCESS CONTROL ALARMS DISPLAY LIVE VIDEO POP-UPS AND SEND EMAIL NOTIFICATIONS TO KEY PERSONNEL

# HAMILTON

BY **GUNNEBO**<sup>®</sup>



*Manufacturers and providers of the latest in drive-up systems, modular vaults, vault doors, night depositories, physical security containers, alarm systems, safe deposit boxes and surveillance equipment.*

1030 Round Bottom Rd., Milford, OH 45150  
Phone 513.874.3733

[hamiltonsecuritysolutions.com](http://hamiltonsecuritysolutions.com)