

# INSTALLATION INSTRUCTIONS



**X-09™**

**Type 1F**

**HIGH SECURITY ELECTRONIC LOCK**

# TABLE OF CONTENTS

---

<b>INTRODUCTION.....</b>	<b>1</b>
Basic Tools and Materials Needed .....	1
Lock Parts for Installation.....	1
Installation Kit Contents .....	2
Template .....	3
Preparation for New Installation of the Lock .....	4
<b>INSTALLATION .....</b>	<b>5</b>
Preliminary Lock Installation.....	5
Cutting the Tubes .....	6
Installation of the Lock .....	7
Installation of the Dial Ring.....	8
Installation of the Cables .....	8
Installation of Generator Cable and Cable Guides .....	9
Installation of the Dial Ring Cover .....	10
Cutting and Installing the Spindle .....	10
Installation of the Dial Hub and Dial .....	12
Attach Back Cover Assembly for Testing .....	14
Installation of the Back Cover Assembly.....	14
Installation Completion Checklist.....	15
Open and Close the X-09 Lock (Factory Combination) .....	15
<b>APPENDIX A - TUBE RETAINER POSITIONS.....</b>	<b>16</b>
<b>APPENDIX B - CABLE ROUTING DIAGRAMS.....</b>	<b>17</b>
<b>APPENDIX C - SMALL SPINDLE HOLE INSTALLATION.....</b>	<b>18</b>

---

# INTRODUCTION

Please read all instructions before you install and use your Model X-09 lock. This will help you avoid unnecessary costs and concerns resulting from improper installation.

## BASIC TOOLS AND MATERIALS NEEDED

1. Small Phillips head screwdriver (#0)
2. Medium Phillips head screwdriver (#1/#2)
3. Standard hacksaw (32 teeth/inch)
4. Six inch metal scale or ruler

### Recommended, but not required:

5. Small flat file
6. Small vise
7. Torque screwdriver (30 inch-pound capacity), or
8. Standard torque wrench with screwdriver bits

**Note:** See table of recommended torques for the various X-09 lock screws.

All other necessary tools and materials are provided.

TABLE OF RECOMMENDED TORQUES FOR THE VARIOUS X-09 LOCK SCREWS			
Applications	P/N	Screw Size	Torque (In.Lb.)
Lock Case Cover	105030	6-32	9.0 to 11.0
Dial Ring Mounting	105034	8-32	17.0 to 20.0
Dial Ring Cover	105034	8-32	17.0 to 20.0
Lock Case Mounting	105046/105195	1/4-20	25.0 to 30.0

## X-09 LOCK PARTS FOR INSTALLATION

1. Lock Assembly
2. Dial Ring Assembly
3. Dial Assembly
4. Spindle
5. Dial Hub Assembly

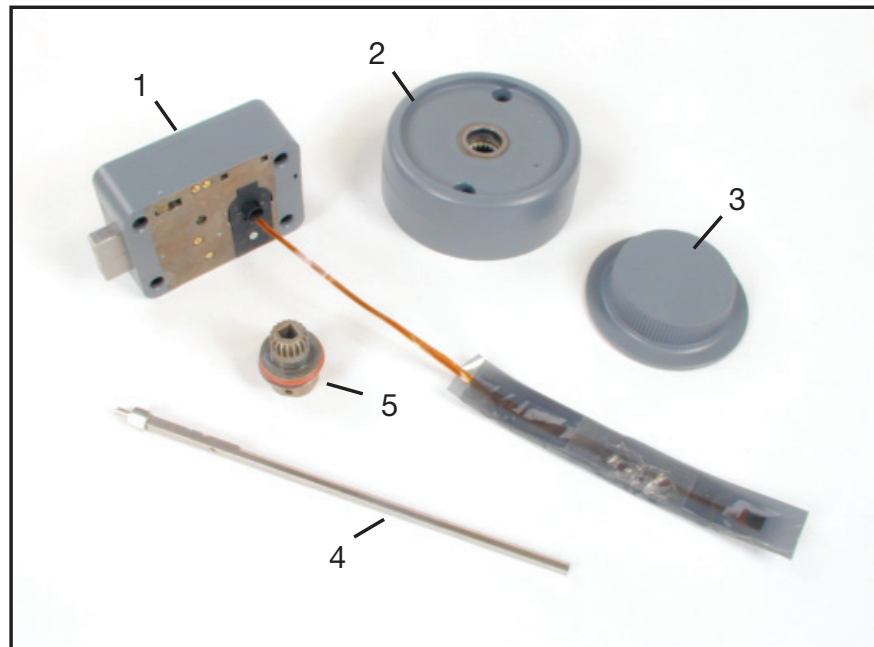

Figure 1 - X-09 Lock Parts

## INSTALLATION KIT CONTENTS

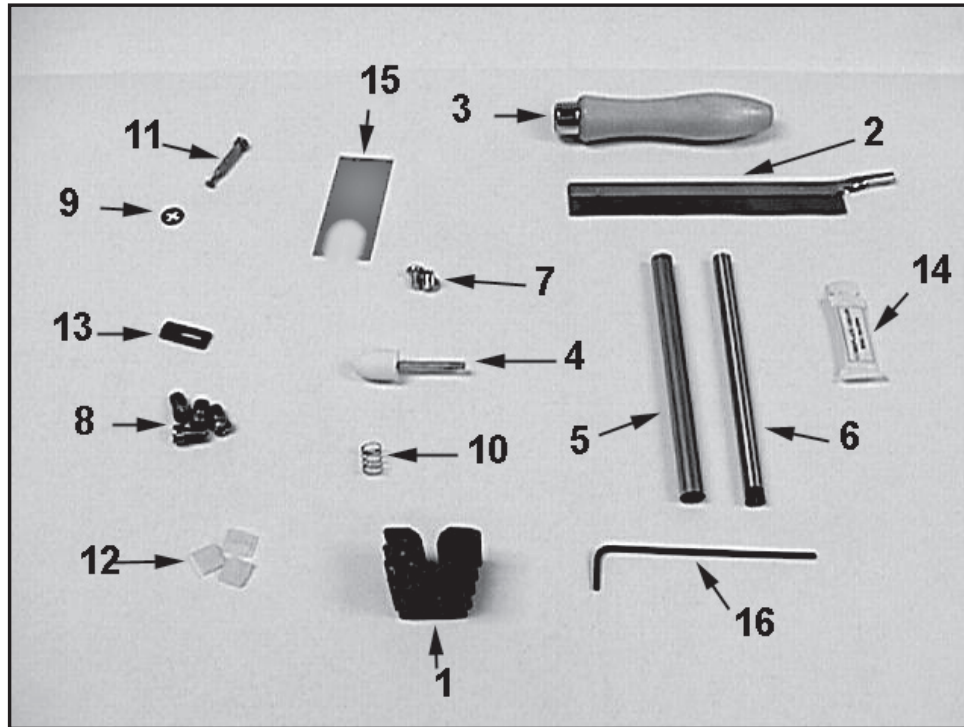

Figure 2 - X-09 Installation Kit

1. Rubber Vise Clamp
2. Saw Blade (52 teeth/inch)
3. Saw Handle
4. Tube Deburr Stone
5. Outer Tube
6. Inner Tube
7. Dial Ring Mounting Screws (2)
8. Lock Case Mounting Screws (4)
9. Cover Lock Pin Retainer
10. Cover Lock Spring
11. Cover Lock Pin
12. Stick-on Cable Guides (3)
13. Zebra Connector & Zebra Connector Housing\*
14. Lubricant
15. Dial Hub Locating Gauge
16. Hex Key (5/64")

\* The Zebra Connector and Zebra Connector Housing are assembled at the factory but may come apart during shipment.

## TEMPLATE

A template is provided as an aid for locating, drilling, and tapping the lock case and dial ring mounting screw holes relative to the spindle hole. Since the lock is designed to fit most industry standard container lock mounting screw hole patterns, the need to use this template should be minimal.

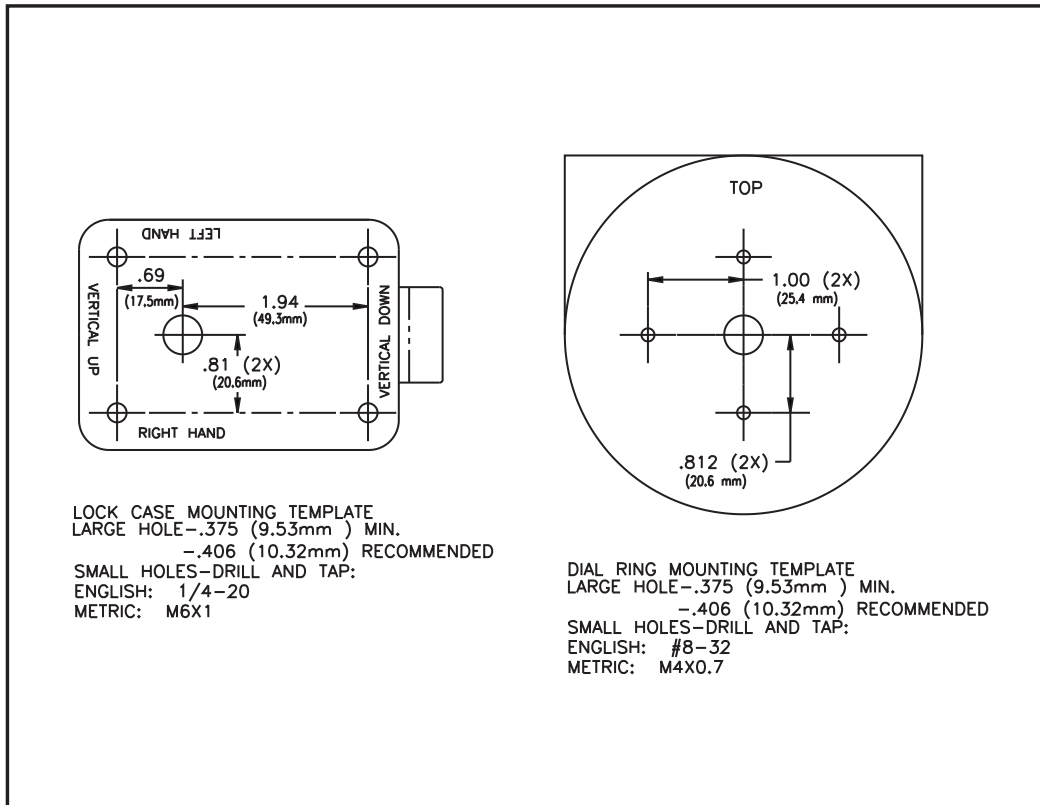

**Note:** The above template is NOT Actual Size. Do Not Use for locating, drilling, and tapping the lock. A Template of actual size is included with the lock for installation purposes.

## PREPARATION FOR NEW INSTALLATION OF THE LOCK

1. Use the template to establish the exact relative locations of all of the necessary mounting holes for the lock case and the dial ring, when necessary.
2. The lock case mounting screws require drilled and tapped 1/4-20 screw holes.
3. The dial ring mounting screws require drilled and tapped #8-32 screw holes.
4. The spindle hole must be 3/8 inch diameter, minimum.

**Note:** *If the spindle hole is less than 3/8 inch, refer to Appendix C of the manual for instruction on small spindle hole installation.*

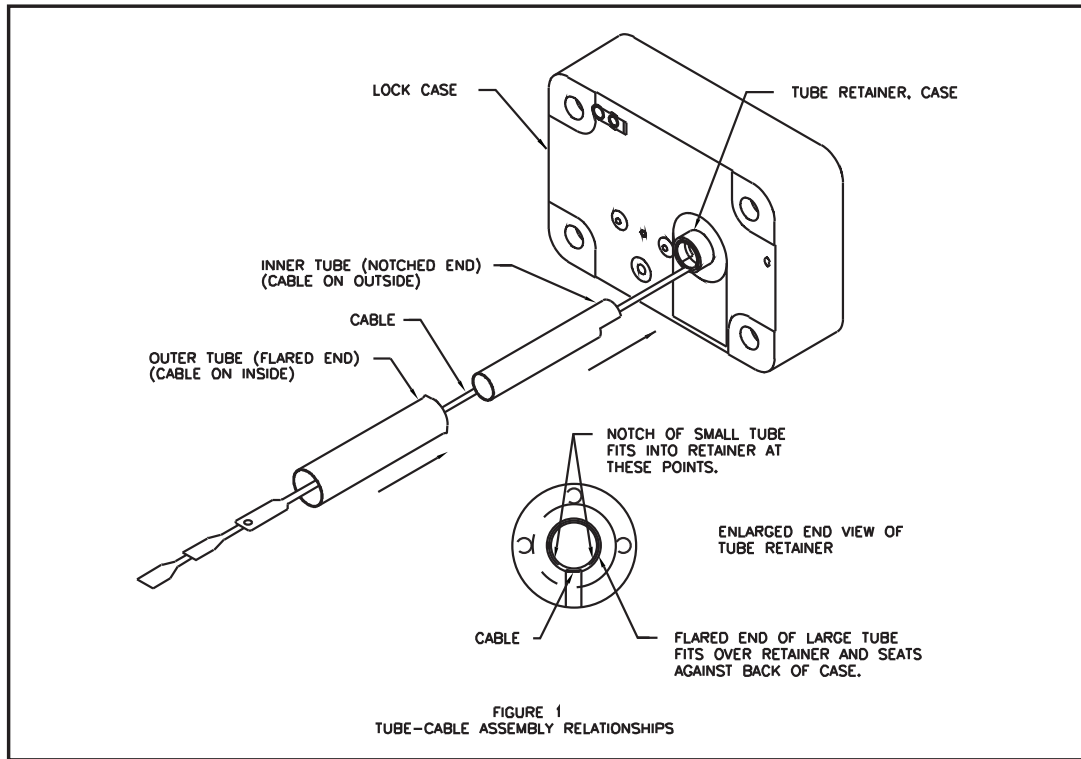

Figure 4- Tube-Cable Assembly Relationships

## PRELIMINARY LOCK INSTALLATION

**WARNING:** The electronics in the X-09 are susceptible to damage from Electro Static Discharge (ESD). Make sure you are properly grounded before removing the lock cover and be careful to avoid touching the connectors on the card.

1. Remove the two screws from the lock back cover assembly. Hold the case and **pull the cover straight out from the lock case so as not to bend any of the motor pins on the card assembly.**

**Caution:** The drive cam assembly is only retained by the lock back cover assembly. Be careful that it does not fall out when the cover is removed.

2. Remove the drive cam assembly from the lock case assembly. (See Figure 5.)
3. Feed the cables through the outer, larger, tube starting from the flared end of the tube. Seat the tube into position on the tube retainer on the back of the lock case assembly. (See Figure 4 ) Be careful to keep the cables pulled taut while seating the tube to avoid pinching damage to them.

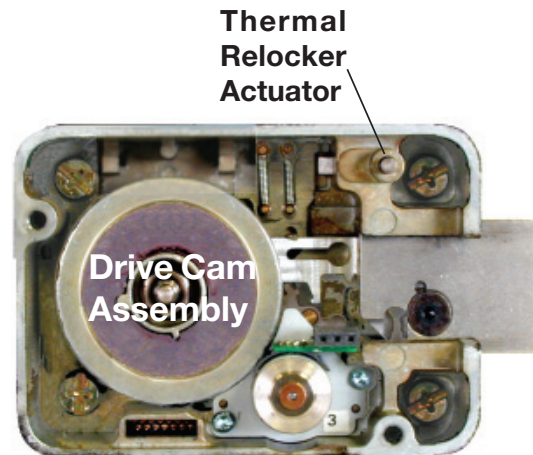

Figure 5 - Inside Lock Case Assembly

**Alternate Method:** Depending on the width of the door, it may be easier to insert the non-flared end of the outer tube through the spindle hole from the inside of the container and feed the cables through the tube. Then seat the flared end of the tube on the tube retainer.

4. Carefully guide the outer tube (keeping it in place on the tube retainer) through the container wall so that the outer tube and the cables are easily accessible at the outside wall of the container.

**Helpful Hint:** If available, another inner tube inserted from the dial ring side, with the cables carefully fed through it, can be very helpful as a guide in feeding the cables through the container wall.

On some containers the only way to complete this step is to retract the bolt. Contact Technical Support for detailed instruction on completing this activity.



5. Loosely attach the lock case assembly to the container wall with two of the four mounting screws, placing them diagonally across from each other.
6. Tighten the lock case mounting screws to hold the lock case in place. (See Figure 6.)



Figure 6 - Tighten Mounting Screws

## CUTTING THE TUBES

**Warning:** *The end of the large tube that is to be discarded must be from the plain (unflared) end of the tube. The end of the small tube that is to be discarded must also be from the plain (unnotched) end of the tube.*

1. Make sure that the outer tube is properly placed over the lock case tube retainer.
2. While holding the outer tube firmly in its seated position, use a 6 inch scale or ruler to measure 5/16 inch from the container wall and mark the outer tube at this length.
3. Remove the lock case assembly from the container and remove the outer tube for cutting.
4. Assemble the saw blade and wooden saw handle provided. To assemble the saw, grip the saw frame in a vise, just below the neck. Drive the handle fully onto the neck. (See Figure 7.) This will reduce the tendency of the handle to turn on the saw frame when sawing.

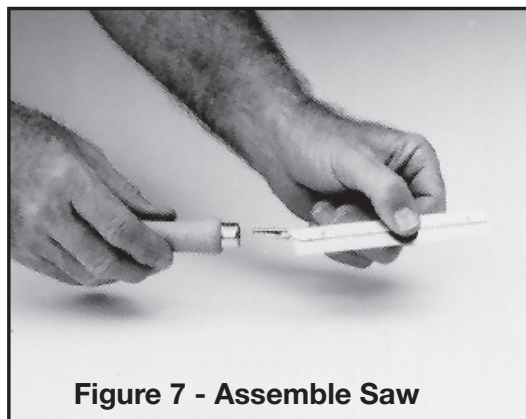

Figure 7 - Assemble Saw

**Note:** This saw is intended only for cutting the tubes. A standard hacksaw should be used to cut the spindle.

5. Insert the tube to be cut into the rubber vise clamp (provided), with the mark just beyond the clamp. Then firmly clamp the rubber vise clamp in a vise. (See Figure 8.) Use the saw to cut the tube where marked. Be careful to keep the cut as straight as possible. Remember the saw only cuts when pushing. Trying to cut while pulling may pull the handle off of the saw blade.

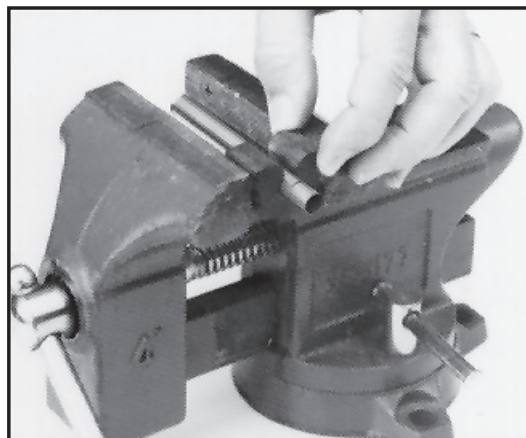
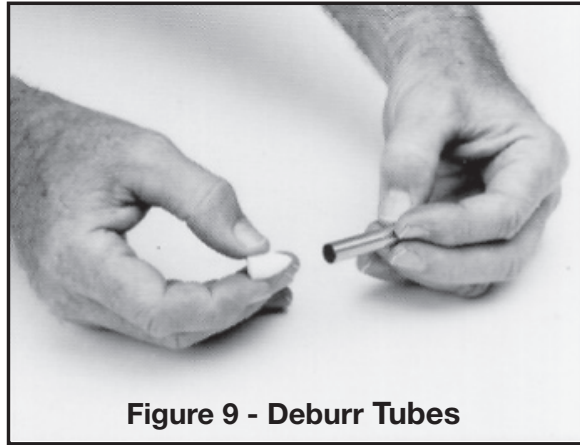

Figure 8 - Cut Tube Using Vise



- The inside and outside of the tubes must be deburred after cutting. Use the stone which is provided for this purpose. Make sure there are no sharp edges on either tube inside and outside so as not to damage the cables. (See Figure 9.)



**Figure 9 - Deburr Tubes**

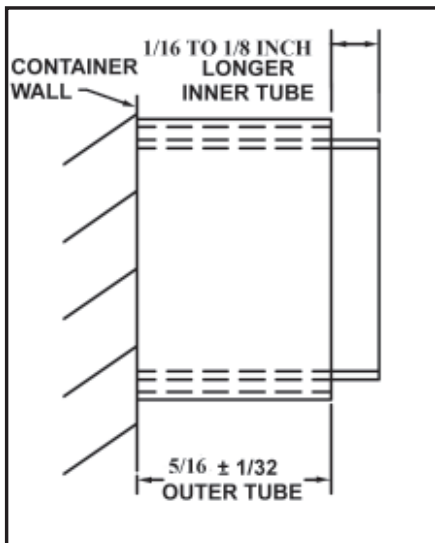

**Figure 10 - Inner and Outer Tubes**

- Install the inner tube on the lock case. Feed the cables through the outer tube and install the outer tube on the lock case. Measure and mark the inner tube to be 1/16 to 1/8 inch longer than the outer tube. (See Figure 10.) Remove the inner tube and cut by the same method as described in Step 5.

**Warning:** *The end of the outer tube that is to be discarded must be from the plain (unflared) end of the tube. The end of the inner tube that is to be discarded must also be from the plain (unnotched) end of the tube.*

## INSTALLATION OF THE LOCK

- Place the inner tube into the lock case tube retainer. Make sure that the cutout in the tube aligns with the cables and allows the tube to seat completely in the tube retainer. (See Figure 11.)
- Feed the cables through the outer tube from the flared end. Seat the tube into position on the tube retainer on the back of the lock case assembly. (See Figure 4 on page 4.) Be careful to keep the cables pulled taut while seating the tube to avoid pinching and damaging them.
- Carefully guide the outer tube (keeping it in place on the tube retainer) through the container wall so that the outer tube and the cables are easily accessible at the outside wall of the container, retracting the bolt if necessary.
- Loosely attach the lock case assembly to the container wall using the lock case mounting screws.
- Tighten the lock case mounting screws to the specified torque. (See Figure 6.)

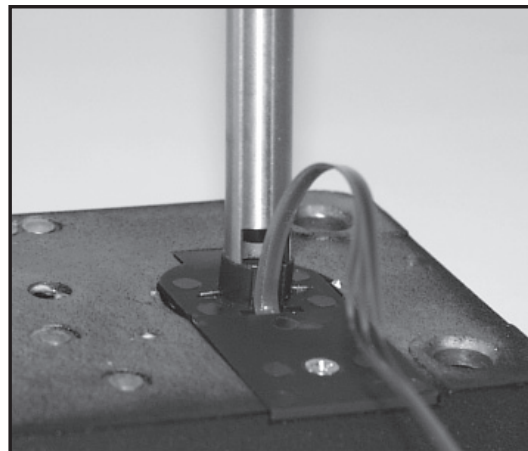

**Figure 11 - Seat Inner Tube in Retainer**

## INSTALLATION OF THE DIAL RING

1. Remove the two screws from the dial ring assembly cover and remove the cover.

---

**Note:** *Make sure the tubes are projecting through the container as shown in Figure 10. If not, the tubes are not seated properly in the lock or they were not cut to the proper length. Correct the problem before proceeding.*

---

2. If necessary, rotate the tube retainer in the dial ring so that the cables come through the notch in the tube retainer. See Appendix A for details.
3. Feed the cables through the tube retainer on the dial ring assembly and place the dial ring assembly over the end of the tubes. Make sure the tubes are seated in the tube retainer on the dial ring assembly.
4. Attach the dial ring to the container with the dial ring mounting screws and tighten to the specified torque.

## INSTALLATION OF THE CABLES

1. Open the ZIF (Zero Insertion Force) seal cover and move the ZIF connector locking actuators outward to their open position. (See Figures 12 and 13.)



Figure 12 - Open ZIF Seal Cover

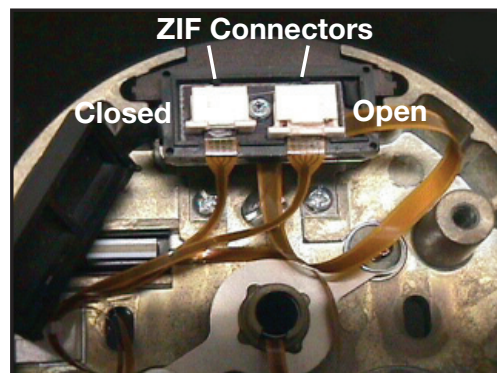

Figure 13 - Closed & Open ZIF Connectors

2. Plug the cables into the ZIF connectors with the bright metal tabs on the cables facing toward the circuit board to which the ZIF connectors are mounted. Push the cables into the connectors as far as they will go.
3. Close the ZIF locking actuators to lock the cables in place.
4. Close the ZIF seal cover. When closing, be sure the tenons in the seal cover align with the holes in the coordinating piece of the seal cover.

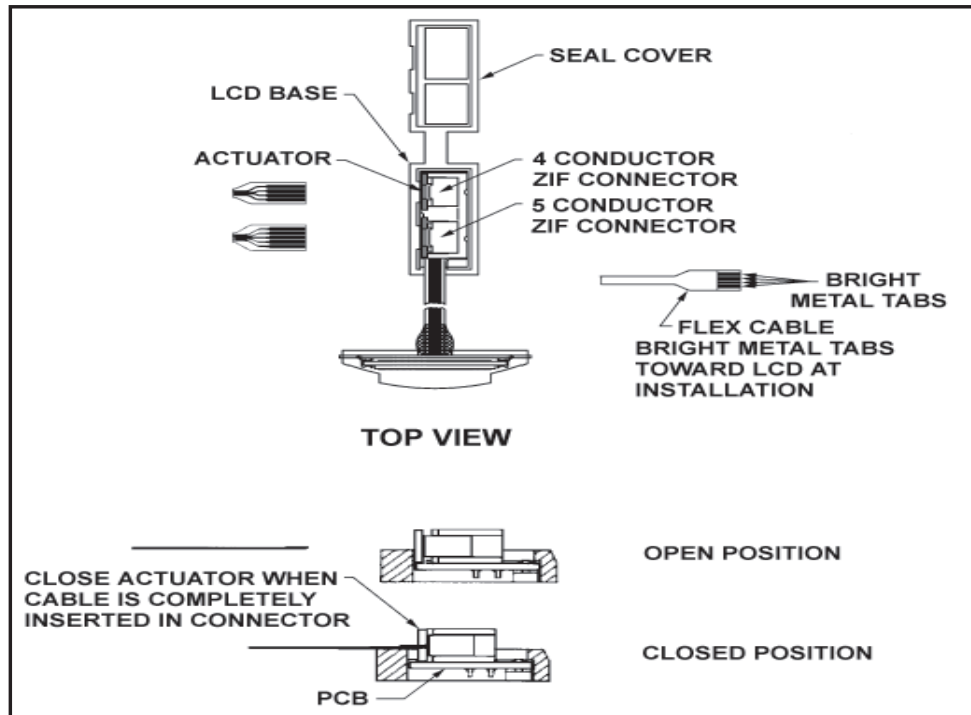

Figure 14 - LCD and ZIF connectors

## INSTALLATION OF GENERATOR CABLE AND CABLE GUIDES

1. Place the generator cable into the dial ring housing recess containing a post used for positioning the cable. (See diagrams in Appendix B.) The hole in the cable must be positioned over the post on the dial ring, and the five gold tabs must be exposed.
2. The Zebra connector and Zebra connector housing are assembled at the factory but may come apart during shipment. If so, insert the Zebra connector back into the Zebra connector housing before proceeding.

**CAUTION: The Zebra connector is an electrical connector. Keep it clean!**

3. Place the generator Zebra connector and connector housing assembly over the generator cable, and press it into the recess. The hole in the Zebra connector housing must be positioned over the post in the dial ring. Be sure that the black Zebra connector housing is positioned as shown in Figure 15.
4. Install at least one of the stick-on cable guides in an appropriate position to restrain the cables. (See Figure 16 for possible locations.)
5. Route the cables through the cable guide that was just installed.

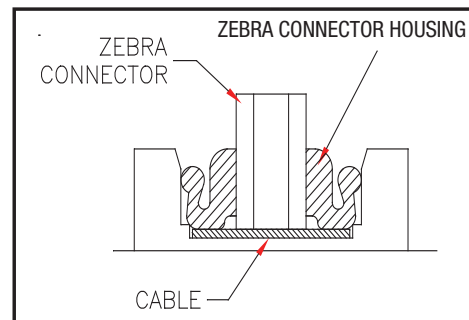

Figure 15 - Zebra Assembly

- Depending on the thickness of the container, additional cable guides may be necessary to ensure the cables are sufficiently restrained. Some possible locations are shown in Figure 16. Install additional guides as needed, and route the LCD and generator cables through them to ensure that the cables do not get routed through the “KEEP CLEAR” area, over the Zebra connector, or near where the geared end of the dial hub will project through the dial ring cover.

---

**Note:** See Appendix B for more detail on routing the cables.

---

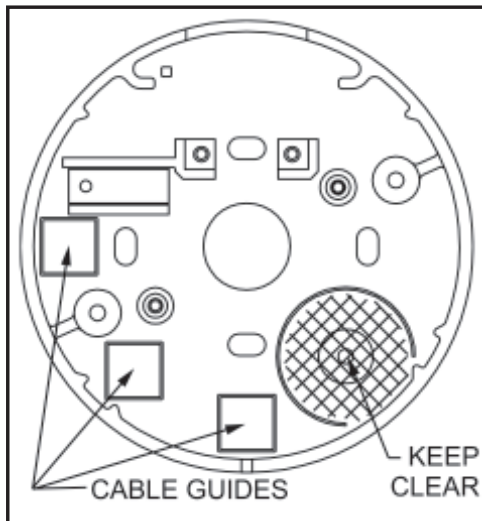

Figure 16 - Cable Guide Locators

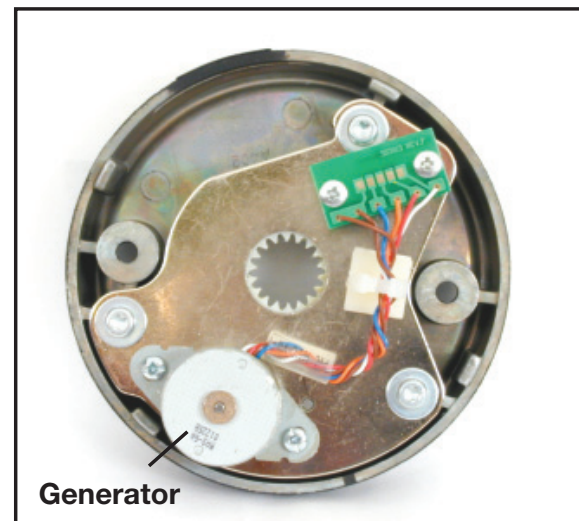

Figure 17 - Dial Ring Cover

## INSTALLATION OF THE DIAL RING COVER

- Align the dial ring cover with the dial ring so that the generator will seat into the five o'clock position and the four aligning lugs align with the corresponding slots in the dial ring. (See Figures 16 and 17.)
- Carefully slide the dial ring cover into the dial ring.
- Hold the dial ring cover in place and tighten the two dial ring cover mounting screws to the specified torque.

## CUTTING AND INSTALLING THE SPINDLE

- Ensure that the lock bolt is extended and remove the cam from the lock case.
- Check the stepper motor gear positioning.

---

**Note:** To avoid unnecessary damage, always make sure that the motor gear is in its proper detent position (see Figures 18 and 19) when inserting the drive cam. If it is not, a pencil may be used to move it to the proper position. This must be done with the lock bolt extended.

---



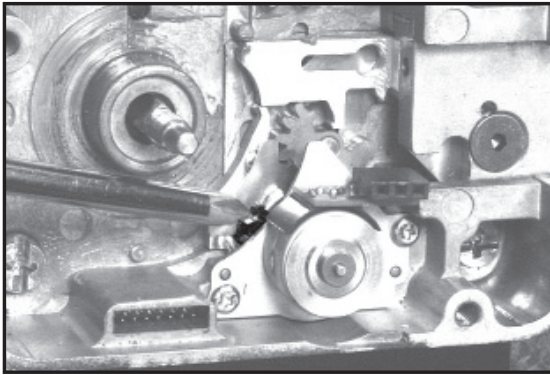

Figure 18 - Wrong Position

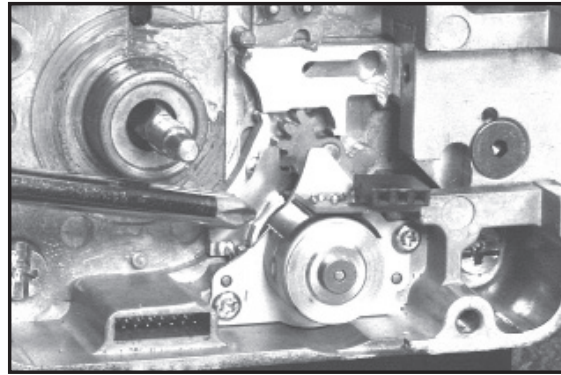

Figure 19 - Proper Position

3. Slide the spindle through the cam and reinsert the drive cam assembly into the lock case and the dial ring cover until the spindle nut is snug against the cam and the cam is seated against the lock case. Note that the square portion of the spindle must be aligned with the square hole in the lock case.

---

**Service Tip:** *If it becomes necessary to remove and reinstall the spindle nut during lock installation or maintenance, the drive cam can be secured by **carefully** placing a #1 Phillips screwdriver between the cam and the lock case. (See Figure 20.)*

---

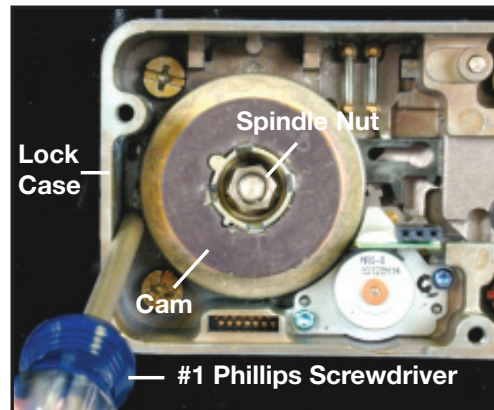

Figure 20 - Secure Drive Cam

4. Slide the dial hub onto the spindle, turning the hub slightly to align the generator drive gear teeth. Hold the drive cam assembly in place while installing the dial hub.
5. Snug down one setscrew to hold the dial hub in place.
6. Mark the spindle flush to the dial hub.
7. Loosen the setscrew and remove the hub.

---

**Alternate Method:** Instead of removing the hub, you may leave it on, using the hub as a vise to hold the spindle while cutting.

---

8. Carefully cut the spindle so that it will be flush to the dial hub after installation.

---

**Caution:** *The spindle should not extend past the dial hub once installed but may be recessed up to 1/32 inch below the surface of the hub. If it extends past the dial hub, it must be filed to flush.*

---

9. Remove all burrs from the end of the spindle.



Figure 21 - Mark Spindle Flush to Hub

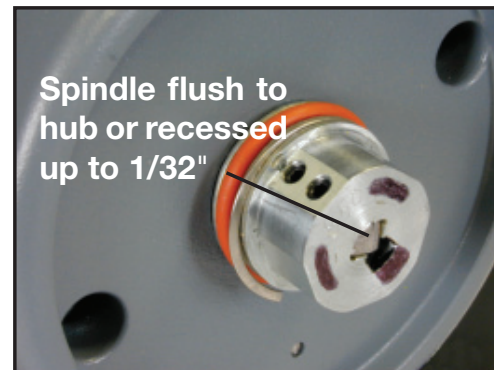

Figure 22 - Spindle Flush or Recessed

## INSTALLATION OF THE DIAL HUB AND DIAL

1. Apply lubricant to the hub bearing surface.
2. While holding the drive cam and spindle in their proper positions in the lock case assembly inside the container, push the dial hub assembly onto the spindle.
3. Make a bend in the dial hub locating gauge at its midpoint. This will keep it from acting as a spring as the hub is positioned for locking to the spindle.
4. Place the Dial Hub Locating Gauge over the spindle and between the dial hub assembly and the bushing in the dial ring cover. This sets up an initial 0.010 inch end play. (See Figure 24.)



Figure 23 - Apply Lubricant to Hub

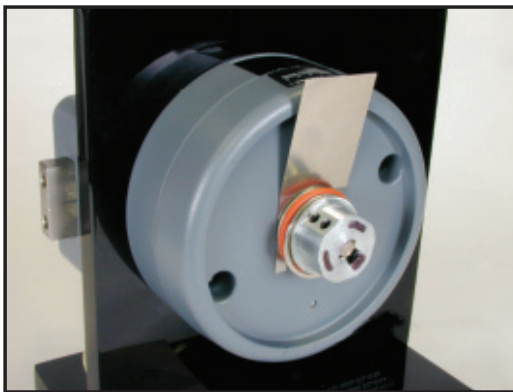

Figure 24 - Place Gauge Between Dial Hub & Bushing



Figure 25 - Maintain Pressure on Spindle Assembly

5. Push the dial hub and the spindle assembly toward each other. (See Figure 25.) While maintaining a constant pressure on them, **SECURELY** tighten the setscrews in the dial hub assembly to 17-20 inch-pounds of torque (a minimum of 1 inch deflection of the handle of the hex key). Tighten the inner setscrew first.

**Caution:** *Tighten in a downward motion in case the hex key should break. (Figure 26.)*



Figure 26 - Tighten Setscrews

6. Remove the dial hub locating gauge.

7. Apply lubricant to the retaining ring on the dial hub assembly and position the retaining ring so that an equal amount of it is consistently exposed around the hub. Also, apply grease from the lubricant tube to the entire ramp area just inside the back of the dial and also to the inner surface of the 5-sided formed clutch spring within the dial. (See Figures 27 and 28.)



**Figure 27 - Apply Lubricant to Ret. Ring**

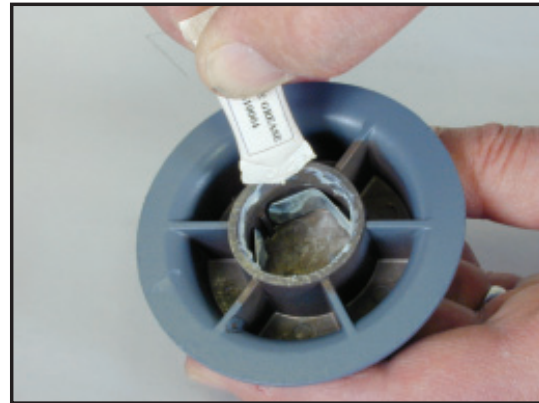
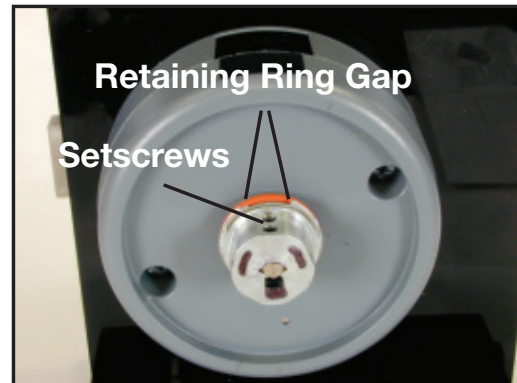

**Figure 28 - Apply Lubricant Inside Dial**

---

**Note:** Ensure that the retaining ring gap is aligned with the setscrews and that an equal amount of the retaining ring is exposed around the hub so the dial can slide easily into place on the hub without interference from the retaining ring. (See Figure 29.)

---



**Figure 29 - Align Retaining Ring**

8. Ensure that the 5-sided flat spring is fully recessed in the dial with the spring gap aligned with the internal key of the dial. (See Figure 30.)

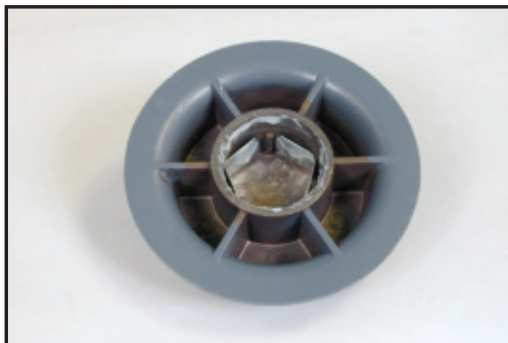

**Figure 30 - 5-Sided Flat Spring in Dial**



**Figure 31 - Apply Pressure to Dial**

9. Carefully align the dial assembly such that the 5-sided formed spring matches the flats of the dial hub assembly. Holding the dial square to the spindle, apply pressure to the dial until the retaining ring seats in the dial. (See Figure 31.)

---

**Note:** You should not be able to pull the dial away from the dial hub assembly. The dial clutch should provide a slip torque of 7 to 25 inch pounds.

---



## ATTACH BACK COVER ASSEMBLY FOR TESTING

1. Install the back cover assembly with the two mounting screws in order to test the operation of the lock. **Do not install the cover lock pin at this time.**

**Caution:** *Take care to align the connectors and the baffle to the hole in the cover.*

---

2. Verify the operation of the lock as described on the following page under **INSTALLATION COMPLETION CHECKLIST.**

## FINAL INSTALLATION OF THE BACK COVER ASSEMBLY

**WARNING:** *Failure to verify that the lock is operational before installing the cover lock pin assembly may cause a lock out condition.*

---

1. Open the lock. (See page 15 for operating instructions.) Leave the bolt in the fully retracted position and remove the back cover assembly.
2. Insert the cover lock pin through the back cover.
3. Install the cover lock spring and retainer clip onto the cover lock pin. The “fingers” of the retainer clip should be angled away from the cover lock spring, and the retainer clip must be seated in the groove of the cover lock pin. (See Figure 32.)

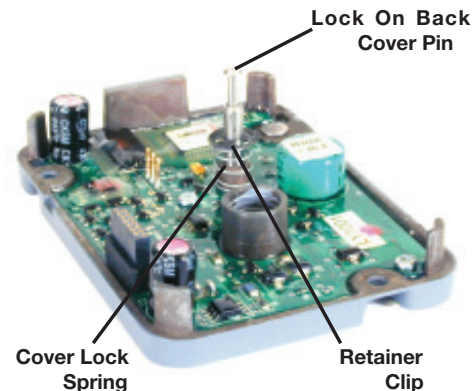

**Figure 32 - Back Cover Assembly**

**Helpful Hint:** A small hammer and the cut off piece from the inner tube can be used to install the spring and clip.

---

**Caution:** *Do not push the clip retainer past the small groove in the cover lock pin. If the clip is not located in the pin groove, it can interfere with pulling the bolt or prevent withdrawal of the pin for normal back cover removal.*

---

4. Record the 6-digit lock serial number in a secure location if you are the end-user. If you are not the end-user, allow the end-user to remove the serial number sticker from the back of the lock when the container has been placed in use.
5. Make sure the bolt is fully retracted and reinstall the back cover with the cover lock pin in place.

**Caution:** *Take care to align the connectors, the baffle to the hole in the cover, and the cover lock pin to the keyhole slot in the bolt rack.*

---

6. Tighten the mounting screws to the specified torque.
7. After restoring the bolt to the extended position, verify that the cover lock pin is fully recessed into the back cover. If not, gently wiggle the cover lock pin to seat it.

## INSTALLATION COMPLETION CHECKLIST

1. Does the dial turn freely without scraping or binding?
2. Have all screws been securely tightened?
3. Operate the lock using the preset factory combination of 50-25-50. See the following section: **OPEN AND CLOSE THE X-09.**

### OPEN AND CLOSE THE X-09 (FACTORY COMBINATION)

CW=Clockwise; CCW=Counterclockwise

---

**Note:** *The viewing angle of the LCD is restricted from either side as a security feature of the lock. This feature restricts viewing of combination dialing by the casual observer. The display may also appear slightly more dim than previous versions of the X-0 series of locks.*

---

#### TO OPEN THE LOCK (using the Factory Combination):

1. Dial **left** (CCW) until lock is “powered”. The lock is considered “powered” when numbers appear on the LCD display screen.
  2. Continue dialing **left** (CCW) to the first number of the factory combination, **50**. Stop on 50 and pause briefly.
  3. Dial **right** (CW) to the second number of the factory combination, **25**. Stop on 25 and pause briefly.
  4. Dial **left** (CCW) to the first number of the factory combination, **50**. Stop on 50 and pause briefly.
  5. Dial **right** (CW). After **OP** with a right arrow (**OP**en right) is displayed, dial to the right to retract the lock bolt.
- 

**Note:** *If at any time the dial remains stationary for more than 40 seconds, the lock will reset (LCD will go blank) requiring the operator to redial the entire combination.*

---

#### TO CLOSE THE LOCK:

1. Turn Dial to the **left** (CCW) a minimum of one complete revolution to extend the bolt.
  2. Turn Dial to the **right** (CW) a minimum of one complete revolution to ensure that it is locked.
- 

**Note:** *The Dial should turn freely in either direction without catching or binding when the bolt is extended and the container is locked.*

---

# APPENDIX A

## TUBE RETAINER POSITIONS

The tube retainer must be positioned so the cables come through the notch in the retainer.

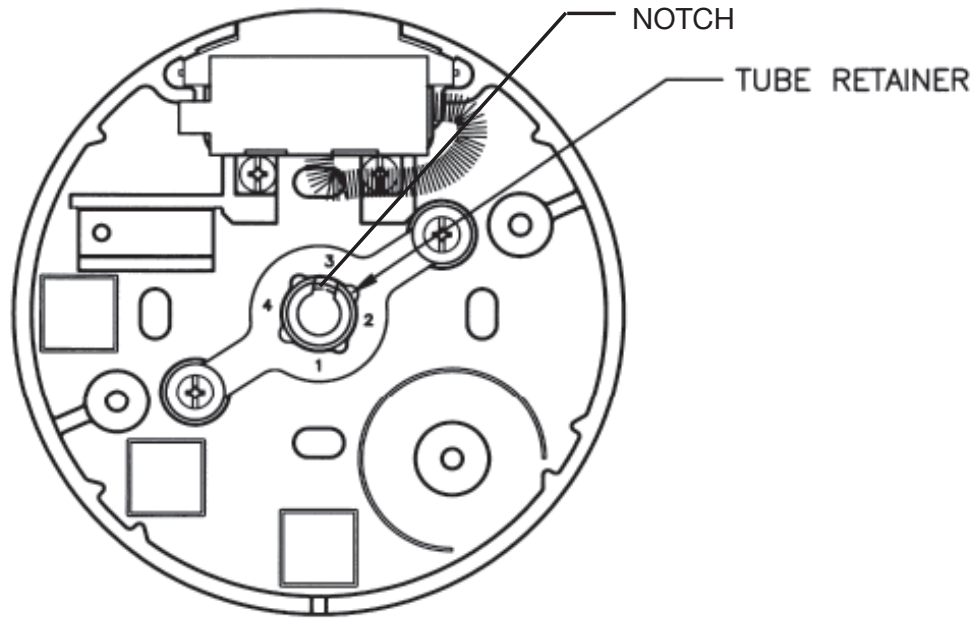

# APPENDIX B

## CABLE ROUTING DIAGRAMS

Refer to the following table and diagrams for suggested cable routing paths to avoid pinching or rubbing of cables. Choose the diagram that most closely represents the thickness of the container door with which you are working. Ensure that the cables are routed so that they do not get pinched by the generator.

Door Thickness	Cable Exit Position	Bolt Position
4 1/2"	3	Left
2 1/2"	1	Right
3/4"	2	Down

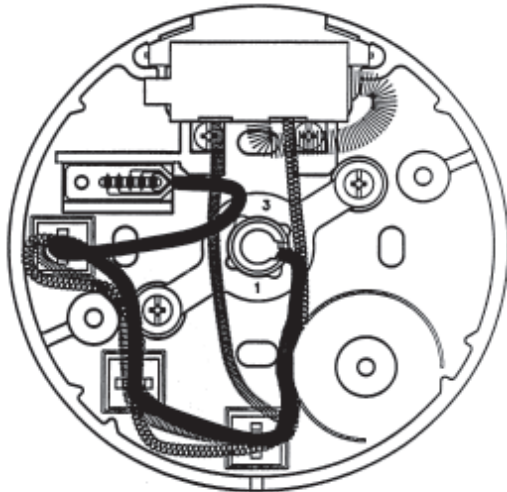

**Dia. 1: 3/4 inch door,  
Cable exit position 2,  
Bolt down.**

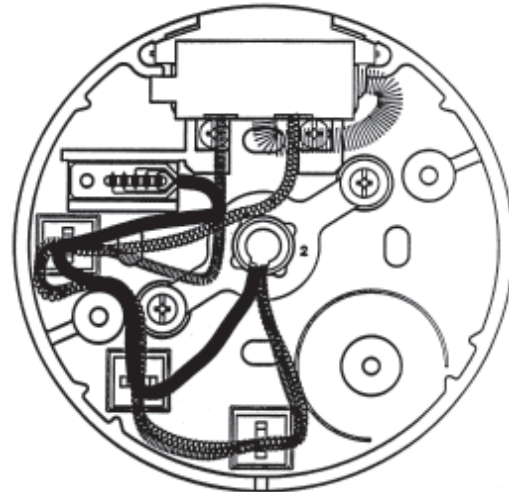

**Dia. 2: 2 1/2 inch door,  
Cable exit position 1,  
Bolt right.**

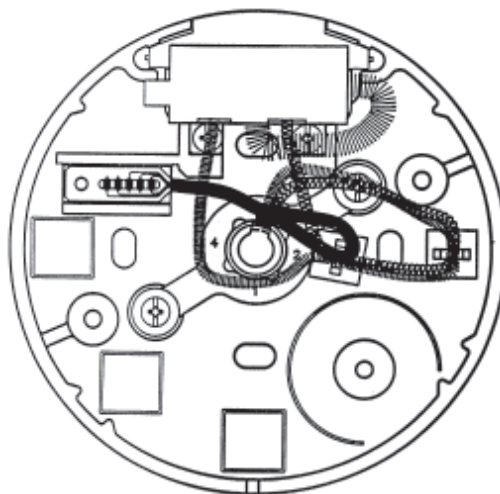

**Dia. 3: 4 1/2 inch door,  
Cable exit position 3,  
Bolt left.**

# APPENDIX C

## SMALL SPINDLE HOLE INSTALLATION

### FUNCTION OF THE INNER AND OUTER TUBES

The tubes of the X-09 protect the cables from mechanical abrasion. The inner tube is positioned between the cables and the spindle while the outer tube is positioned between the cables and the holes through the hardplate and container skin. The outer tube also protects the cables in terms of electromagnetic radiation, preventing signals coming from the lock and shielding the lock from external signals sent to it.

### CONTAINERS WITH SMALL SPINDLE HOLES

Some GSA approved containers have spindle holes that are too small for the outer tube of the X-09 to pass through. Usually, these are Mosler containers manufactured between late 1986 and October 1990. The approved method of installing an X-09 in such containers is similar to the method for installing an X-07. The outer tube is cut very short, its flared end rests on the face of the container, and its non-flared end seats in the tube retainer on the dial ring assembly. **The outer tube must be installed in this manner. It may not simply be omitted.**

### PREPARE & INSTALL TUBES

For small spindle hole installation, start the installation of the lock as you would normally by following the instructions in the Installation manual through Step 2 of the section entitled "PRELIMINARY LOCK INSTALLATION". After completing Step 2 of that section, proceed with the following instructions to prepare and install the inner and outer tubes.

1. Place the flared end of the outer tube over the spindle hole on the outside face of the container.

---

**Note:** *On some containers the outer tube will actually be placed on an extension of the hardplate box that is built into the container.*

---

2. Use a 6 inch scale or ruler to measure 5/16 inch from the container wall and mark the outer tube at this length.
3. Assemble the saw blade and wooden saw handle provided. To assemble the saw, grip the saw frame in a vise, just below the neck. Drive the handle fully onto the neck. This will reduce the tendency of the handle to turn on the saw frame when sawing.

---

**Note:** *This saw is intended only for cutting the tubes. A standard hacksaw should be used to cut the spindle.*

---

4. Insert the tube to be cut into the rubber vise clamp (provided). Then firmly clamp the rubber vise clamp in a vise. Use the saw to cut the tube where marked. Be careful to keep the cut as straight as possible. Keep in mind that the saw only cuts when pushing. Trying to cut while pulling may pull the handle off of the blade.

---

**Caution:** *Discard only the plain (unflared) end of the outer tube.*

---

5. Use the stone that is provided to deburr the inside and outside of the tube. Make sure that there are no sharp edges so as not to damage the cables.
6. Insert the notched end of the inner (smaller) tube into the tube retainer on the lock case. Make sure that the notch in the tube aligns with the cables and allows the tube to seat completely into the tube retainer without pinching or crimping the cables.
7. Carefully guide the cables and inner tube through the container spindle hole from the inside of the container. **Be very careful not to pinch, crimp, or cut the cables.**

---

**Helpful Hint:** *Placing another inner tube over the cables will help guide them undamaged through the spindle hole.*

---

8. Loosely attach the lock case assembly to the container wall with two of the four mounting screws, placing them diagonally across from each other.
9. Mark the inner tube for cutting 13/32 inch, +/- 1/32", out from the face of the container.
10. Remove the mounting screws from the lock case and then remove the lock case and inner tube from the container.
11. Cut and deburr the inner tube using the same method as described previously for the outer tube. (Refer to steps 4 and 5.)

---

**Caution:** *Discard only the plain (unnotched) end of the inner tube.*

---

12. Reinsert the notched end of the inner tube into the tube retainer on the lock case.
13. Use the tape that is provided in the installation kit to tape the cables and tube retainer to the inner tube. This will protect the cables from the rough edges of the spindle hole and will secure the tube to the lock case.
14. Once again, carefully guide the cables and inner tube through the container spindle hole from the inside of the container
15. Loosely attach the lock case assembly to the container wall, this time using all four lock case mounting screws.
16. Tighten the lock case mounting screws to the specified torque. (See Pg. 1 of the Installation Guide.)

17. Place the flared end of the outer tube over the cables and inner tube, and seat it against the face of the container.
18. Continue with the installation of the lock by returning to the X-09 Installation Instructions and proceeding to the section entitled "INSTALLATION OF THE DIAL RING" (Pg. 8). You can follow the Instruction manual for the remainder of the installation process for the lock.





Document Number 521.021

Rev. E - 9/08

---

**Notice:** The information in this manual is subject to change without notice and does not represent a commitment on the part of Kaba Mas. Kaba Mas shall not be liable for technical or editorial errors or omissions contained herein; nor for incidental or consequential damages resulting from the furnishing, performance or use of this material.

---

© 2002-2008 Kaba Mas

All rights reserved



Kaba Mas LLC  
749 W. Short Street,  
Lexington, KY 40508 USA  
Phone: 859-253-4744 FAX: 859-255-2655  
Technical Support: 800-950-4744  
[www.kaba-mas.com](http://www.kaba-mas.com)