

HAMILTON AIR®

7775 Copper Road • Cincinnati, Ohio 45242 • 513-874-3733

Model HA1000-XLR

Video Mount Installation Manual



Doc#08-382

Video Mounting Arm Assembly Details

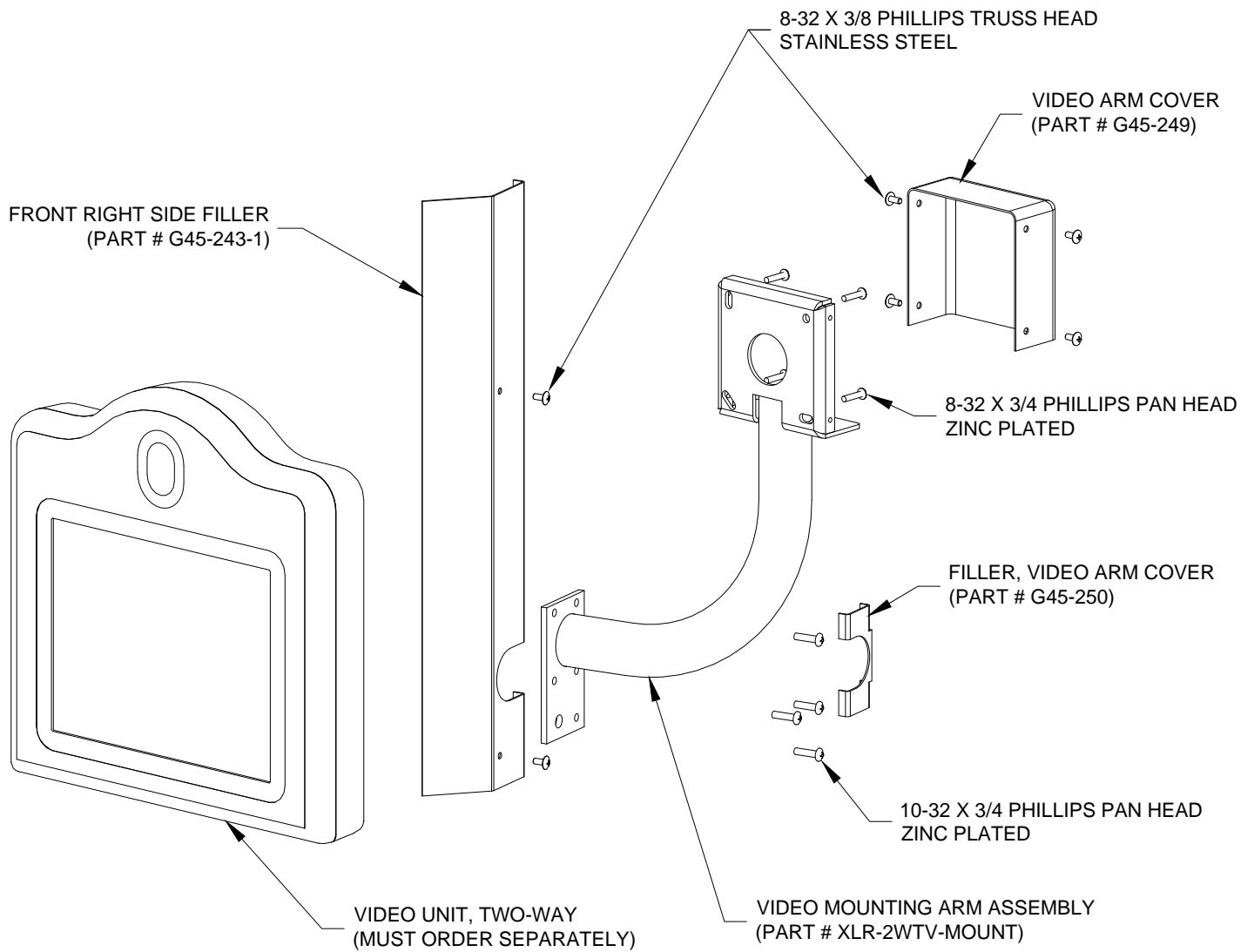

Basic Installation Procedures

- 1) Remove lower front cover panel from customer unit.
- 2) Remove right side front stainless trim panel from customer unit.
- 3) Remove two 10-32 x 1/4 phillips pan head screws that attached the lower right pocket to the stainless steel back panel.
- 4) Attached video mounting arm to customer unit with four 10-32 x 3/4 phillips pan head screws provided.
- 5) Install video unit to the mounting arm using instructions and screws provided with video unit.
- 6) Connect all wires using instructions provided with video unit and route them through the mounting arm tube.
- 7) Install video arm cover behind video unit. Seal this cover to video unit to prevent water entry.
- 8) Install filler to back side of video arm tube and then install front right side cover stainless panel.
- 9) Install lower front cover.



Optional Video Power and Control

Note, Only used with Hamilton 5517 two-way video units.

E10036 Video Power Control Cable Installation

Used only for 5517 video units when pneumatic tube system uses E0873-C I/O control boards.

