

# Ikegami

## ISD-A15S

Hyper Wide Light Dynamic  
Compact Cube Day/Night Camera



### HYPER HD DYNAMIC

As the newest addition to the Ikegami Hyper Dynamic Camera Series, Model ISD-A15S features an extremely wide light dynamic range, high sensitivity and high resolution enabled by a 1/3.2-inch CMOS sensor and Ikegami's digital processing technology. It is a Hyper Wide Light Dynamic Range Box Camera that reproduces a clear and natural image even in locations where there is a significant difference in the intensity of illumination, such as window areas, or in lobby entrances of buildings. ISD-A15S comes with a compact cube body, giving it the flexibility for a broad array of locations and equipment, such as ATM machines and outdoor housings.

## FEATURES

### Hyper Wide Light Dynamic Range (Hyper WDR)



The Hyper WDR function provides for very effective compensation of high light and dark areas in screen. This situation may occur generally outside or viewing from indoor to outside scenes. Even in large light fluctuations, bright-and-dark objects can be captured and viewed clearly with a natural color.

### Compact Body of Super Cube

This camera comes with a compact cube body, that is suitable for the locations such as ATM machines.



### Defog Function



Defog functions to capture clear images when the entire video looks foggy.

### High-quality Picture and High Resolution



The camera is designed for smear-free imaging and low noise. The Digital Signal Processor, effectively enhances details, which achieves crisp and sharp images with a high signal-to-noise ratio. The high resolution of a horizontal resolution of 700TVL is assured.

# ISD-A15S

Hyper Wide Light Dynamic  
Compact Cube Day/Night Camera

## Specifications

<b>Image Sensor</b>	1/3.2-inch CMOS sensor
<b>Pixel Number</b>	Approx. 1.23M pixels, 1,280 (H) x 960 (V)
<b>Scanning System</b>	NTSC: 525 TV lines/59.94 Hz, 2 : 1 interlaced PAL: 625 TV lines/50 Hz, 2 : 1 interlaced (Factory option)
<b>Sync System</b>	Internal Sync (Crystal Lock)
<b>Video Output</b>	VBS 1.0 Vp-p/75 ohms
<b>Horizontal Resolution</b>	700 TV lines
<b>S/N Ratio</b>	50 dB (p-p/rms) or better
<b>Minimum Illumination</b>	0.1 lx/F1.4 (Color, VBS output 50%) 0.02 lx/F1.4 *ISD-A15S-TDN (B/W, VBS output 50%)
<b>Day &amp; Night Function</b>	Built-in, AUTO/MANUAL selectable True Day/Night (ISD-A15-TDN), Digital Day/Night (ISD-A15)
<b>Wide Dynamic Range</b>	Built-in, and Variable
<b>AGC</b>	ON (AGC, HYPER-AGC) / OFF (LOW, MID, HIGH), selectable
<b>Defog function</b>	Built-in
<b>White Balance Control</b>	ATW(Indoor/Outdoor/AUTO1/AUTO2)/PUSH/PUSHLOCK/MANUAL
<b>Detail Correction</b>	Built-in
<b>Digital Noise Reduction</b>	Built-in, ON / OFF selectable (DNR Function)
<b>Color Rolling Reduction Function</b>	Built-in, ON / OFF selectable (CRR Function)
<b>Privacy Masking</b>	Built-in (Maximum 16 zones)
<b>Camera ID</b>	Up to 24 characters (alphanumeric and symbols)
<b>Lens Mount</b>	CS Mount (C Mount adaptor is available as an option.)
<b>Auto Iris Function</b>	DC Iris (DC Iris level adjustable)
<b>Lens Flange Focus</b>	Built-in and adjustable
<b>Power Requirement</b>	AC24V ±10%, 50/60Hz DC12V (10.5 to 15V)
<b>Power Consumption</b>	2.0W
<b>Operating Temperature and Relative Humidity</b>	-10 to +50°C (13.5 to 122°F), RH 30 to 90% (No Condensation)
<b>Dimension (W x H x D)</b>	52 x 52 x 55 mm (2.05 x 2.05 x 2.16 inches), excluding protrusions
<b>Weight</b>	200g (Approx. 0.44 lbs)
<b>Input/Output Connectors</b>	VIDEO OUT -- BNC LENS -- 4P (applicable plug E4-191J-150 or equivalent) DC12V/AC24V input -- 2P
<b>Standard Accessories</b>	Instruction Manual, Hexagonal Wrench for flange focus adjustment

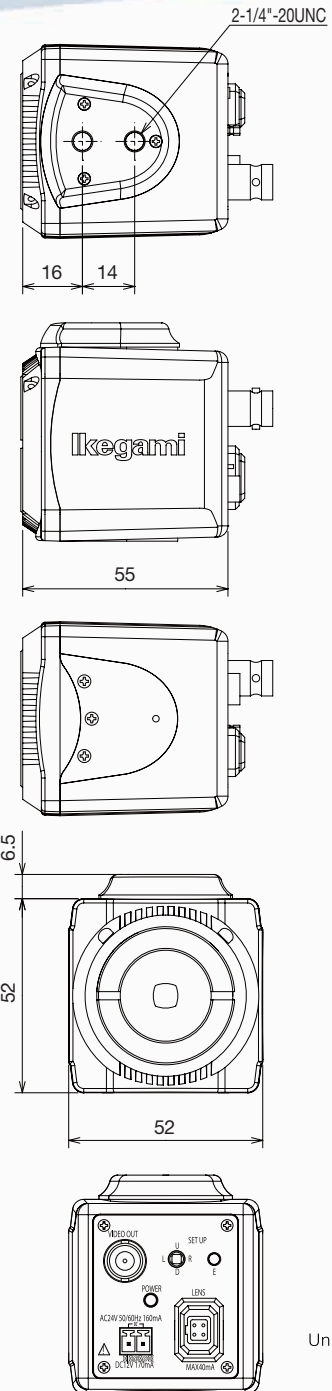

Unit:mm

\* Specifications and design are subject to change for product improvements without notice.

Design and specifications are subject to change without notice.

### Ikegami Tsushinki Co.,Ltd.

■ URL : [www.ikegami.co.jp/en/](http://www.ikegami.co.jp/en/)

- Head Office : 5-6-16 Ikegami, Ohta-ku, Tokyo 146-8567, Japan .....TEL.+81-(0)3-5700-1111 / FAX.+81-(0)3-5700-1137
- Overseas Sales Division : 5-6-16 Ikegami, Ohta-ku, Tokyo 146-8567, Japan .....TEL.+81-(0)3-5700-4117 / FAX.+81-(0)3-5748-2200
- Beijing Office : Room No.307 Tower B, Jia Tai International Mansion No.41East Fourth Ring Road, Chaoyang District, Beijing China ...TEL.+86-(0)10-85710350 / FAX.+86-(0)10-85711804

### Ikegami Electronics (U.S.A.), INC.

■ URL : [www.ikegami.com](http://www.ikegami.com)

- Headquarters : 300 Route 17 South, Mahwah, NJ 07430, U.S.A. ....TEL.+1-201-368-9171 / FAX.+1-201-569-1626

### Ikegami Electronics (Europe) GmbH

■ URL : [www.ikegami.de](http://www.ikegami.de)

- Headquarters : Ikegami Strasse 1, D-41460 Neuss, Germany ..... TEL.+49-(0)2131-1230 / FAX.+49-(0)2131-102820
- U.K. Branch : 1 Windmill Business Village, Brooklands Close, Sunbury on Thames, TW16 7DY, England ..... TEL.+44-(0)1932-769700 / FAX.+44-(0)1932-769710

### Ikegami Electronics Asia Pacific Pte.Ltd. ■ URL : [sg.ikegami.co.jp](http://sg.ikegami.co.jp)

- Headquarters : 1 Tampines Central 5, #03-03 CPF Tampines Building, Singapore 529508 .....TEL.+65-6260-8820 / FAX.+65-6260-8896

A000A000-AA

